

# KUBOTA Earthquake Resistant Ductile Iron Pipe (ERDIP)

3" ~ 104" (75 ~ 2600mm)



## KUBOTA Corporation

Pipe Systems Global Marketing & Sales Dept.

1-3, Kyobashi 2-chome, Chuo-ku, Tokyo, 104-8307, JAPAN

Tel : +81-3-3245-3111

Website : <https://www.kubota.com/products/ironpipe/>

E-mail : [kbt\\_g.ironpipe@kubota.com](mailto:kbt_g.ironpipe@kubota.com)

## KUBOTA Membrane USA Corporation

ERDIP Dept. / LA Office

3460 Torrance Boulevard, Suite 302

Torrance, CA 90503, USA

Tel : +1-424-358-5200

Website : <https://www.kubota-membrane.com/page/erdip>

E-mail : [kbt\\_g.erdip-usa@kubota.com](mailto:kbt_g.erdip-usa@kubota.com)

Ductile Iron Pipes  
WEBSITE



facebook



# KUBOTA Corporation

# “Earthquake Resistant” For safe and secure life

Kubota is a leading manufacturer of a wide range of technically advanced products for water systems in cities, industry and irrigation. In 1893 Kubota began supplying iron pipes for the safe delivery of drinking water in Japan. Since then Kubota has been working continuously on technical innovation and developing superior pipe products so that in 1974, Kubota released the world’s first Earthquake Resistant Ductile Iron Pipe (ERDIP).

Kubota’s ERDIP which can be used for anything from distribution lines to trunk lines, and ranges in size from 3 to 104 inches (75 to 2600 mm), has had no documented failures or leaks caused by earthquakes, including the 2011 Great East Japan earthquake which measured 9.0 on the Richter scale. This excellent seismic performance is why Kubota’s ERDIP is used by so many Japanese water agencies today.

Since its introduction the volume of ERDIP produced by Kubota has increased steadily with marked growth beginning after the 1995 Kobe earthquake. ERDIP has become so popular that it now accounts for over 90% of the ductile iron pipe market in Japan, with over 41,000 miles of ERDIP pipe being installed so far. That’s enough to go around the world one and half times! We have also started to see ERDIP being adopted by municipalities in the U.S., Canada, Singapore and Nepal and so on today.

Besides its earthquake resistant purpose, ERDIP also performs effectively against ground displacement caused by other disasters such as landslides, subsidence, hurricanes, liquefaction etc. This is why our ERDIP is also known as Hazard Resilient Ductile Iron Pipe (HRDIP).

We are confident that our unique ERDIP product will help improve the resiliency and reliability of our owners’ water supply for years to come.



Earthquake Resistant Ductile Iron Pipe (ERDIP)

## Concept

The Earthquake Resistant Ductile Iron Pipe (ERDIP) absorbs the large ground displacement such as ground subsidence and crack by joints extension/contraction, deflection, and anti-pull out structure. When one joint fully extends at the event of large earthquakes, the joint can pull the next pipes one after another like a buried chain. Therefore, this pipeline is called chain structure pipeline.

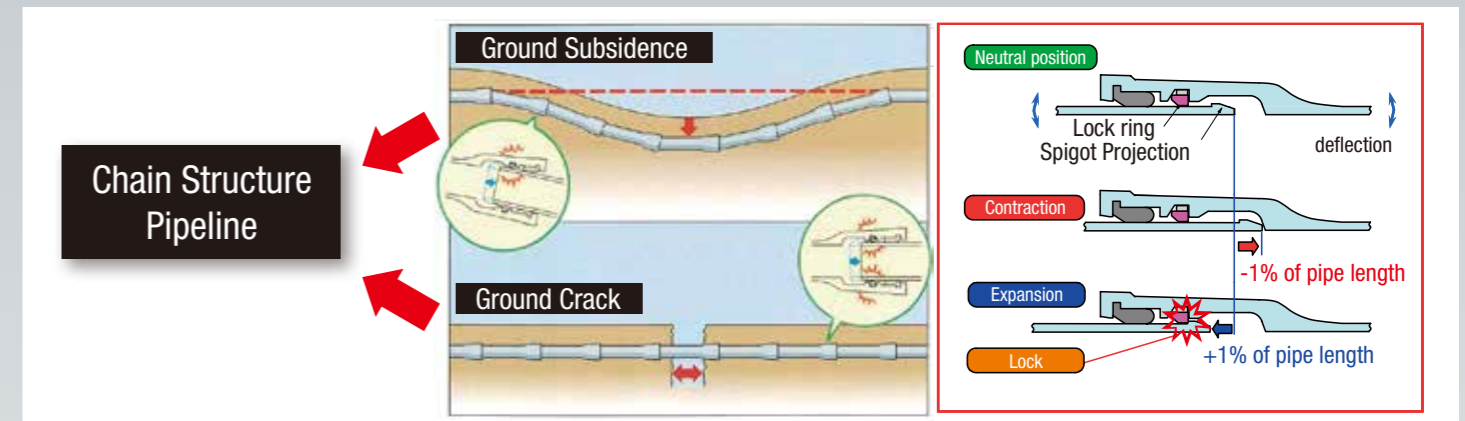

## Performance of the Joint

The joint performance of ERDIP is the highest rank in ISO 16134:2020.

Property	Performance	ISO 16134:2020
Amount of expansion/contraction	±1% of L	Class S-1
Pull-out resistance	3D kN 17,100D <sub>in</sub> (lbf) [3D <sub>mm</sub> (kN)]	Class A
Joint deflection angle	8° *1	Class M-1

Note) L : Nominal pipe length  
D<sub>in</sub> : Nominal diameter of pipe (inches)  
D<sub>mm</sub> : Nominal diameter of pipe (millimeters)  
\*1) In case of size 3”~16”

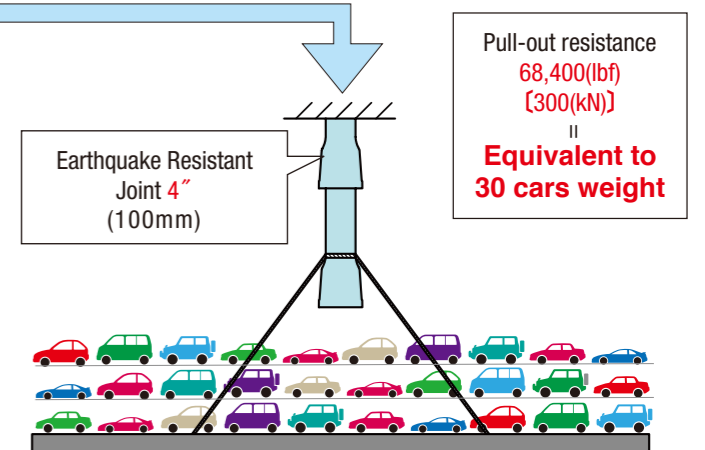

## No failure

ERDIP has had no documented failures during the past seismic events including the 1995 Kobe earthquake, the 2011 Great East Japan earthquake, and many other earthquakes.



# Lineup of ERDIP

## Pipes

**GENEX®**

Nominal Diameter  
**3" ~ 16"**  
(75mm) ~ (400mm)

Push-on joint

Wall Thickness: D1/DS

6", 8" and 12" are available in AWWA size

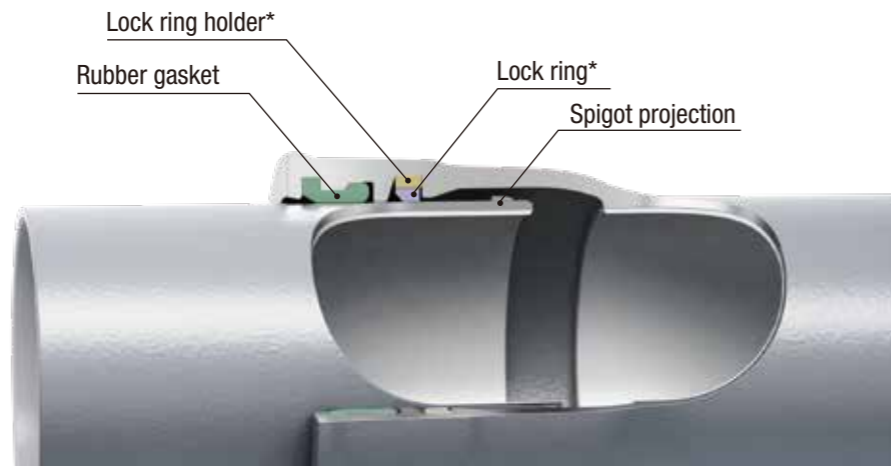

※External coating: C-protect

\*Lock ring / Lock ring holder are preset

## Fittings

**GENEX®**

Nominal Diameter  
**3" ~ 16"**  
(75mm) ~ (400mm)

Mechanical joint

6", 8" and 12" are available in AWWA size

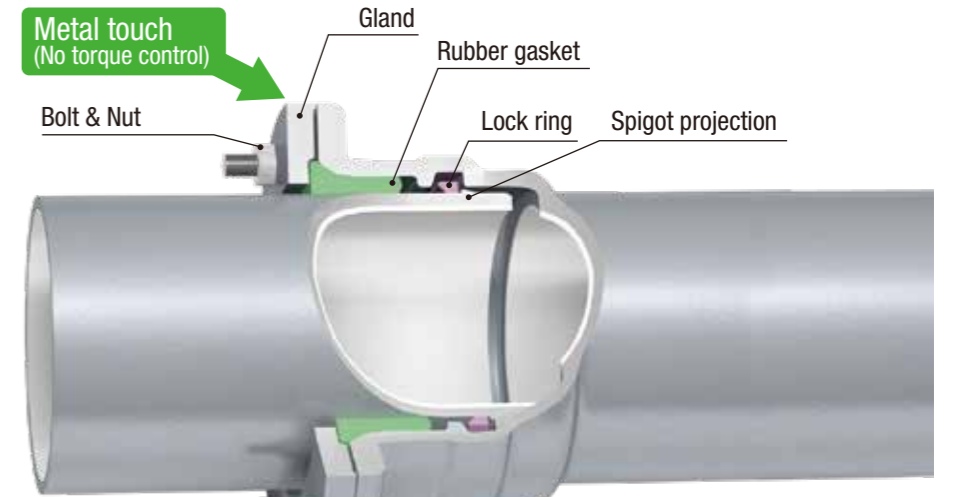

※External coating: C-protect

\*Lock ring is preset.

**N S**

Nominal Diameter  
**20" ~ 40"**  
(500mm) ~ (1000mm)

Mechanical joint

Wall Thickness: DS

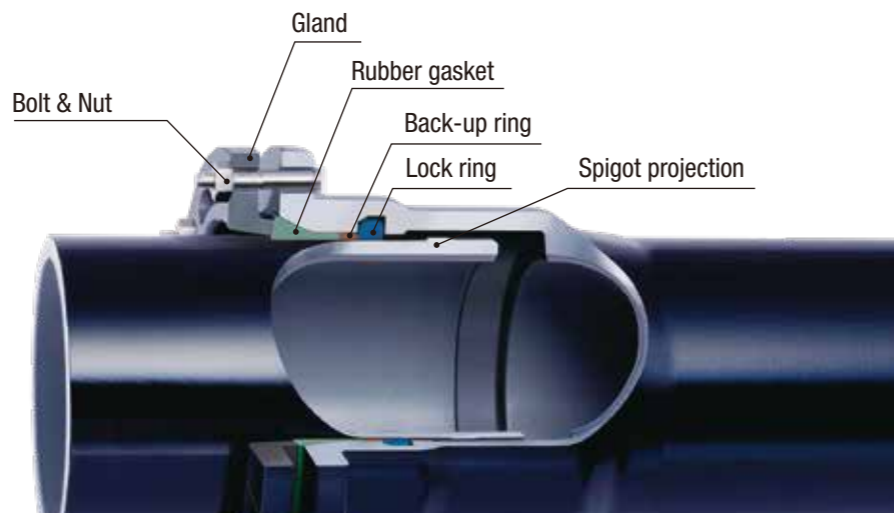

**N S**

Nominal Diameter  
**20" ~ 40"**  
(500mm) ~ (1000mm)

Mechanical joint

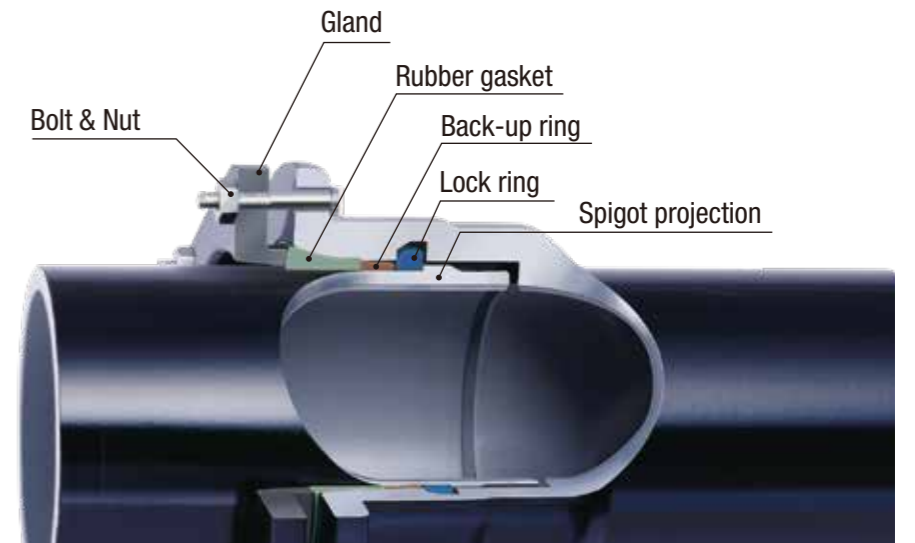

**S**

Nominal Diameter  
**44" ~ 104"**  
(1100mm) ~ (2600mm)

Mechanical joint

Wall Thickness: D1/D2/D3

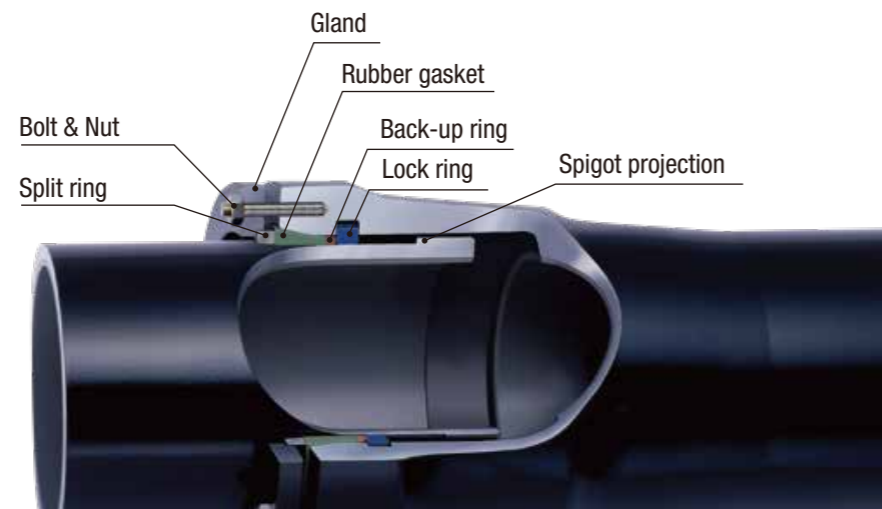

**U F**

Nominal Diameter  
**32" ~ 104"**  
(800mm) ~ (2600mm)

Mechanical joint

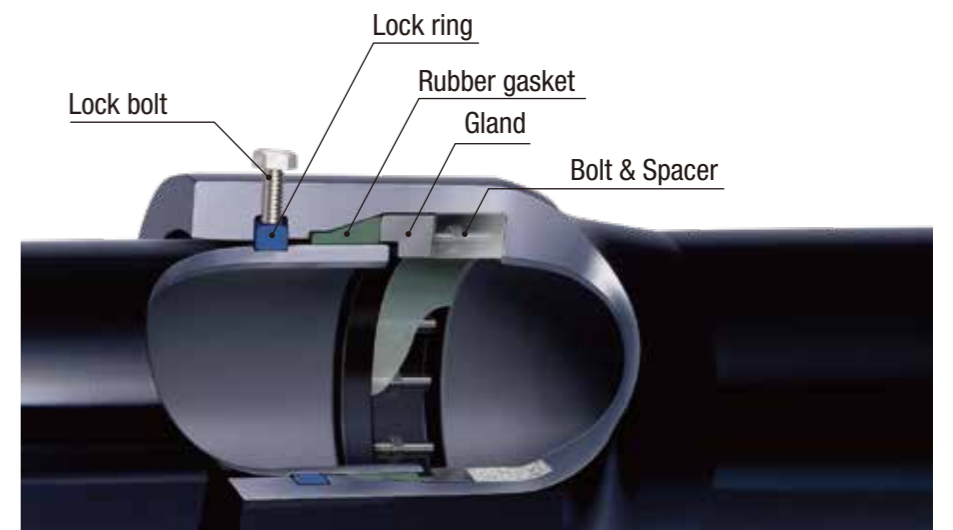



# External coating

Pipes and fittings will be coated externally as the following table.

GENEX® 3"~16" (75mm~400mm) C-protect	NS 20"~40" (500mm~1000mm) Zinc rich paint followed by a synthetic resin paint	S 44"~104" (1100mm~2600mm) Zinc rich paint followed by a synthetic resin paint
--	---	--

# C-protect (anti-corrosion external coating)

- C-protect (External coating) has excellent anti-corrosion performance.
- C-protect also has self-healing performance against scratches through the effect of sacrificial protection.
- C-protect is made of Zinc alloy, and synthetic resin coating.

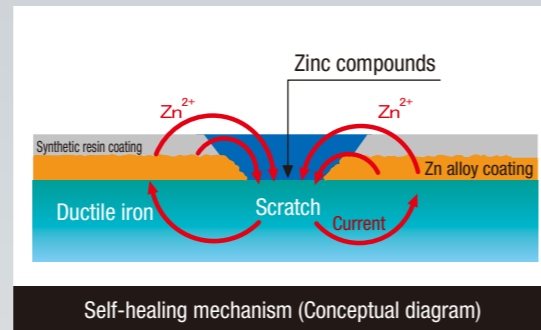
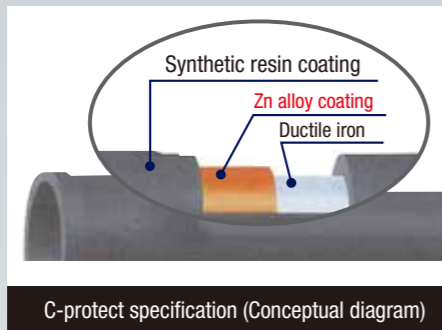

# Installation

ERDIP can be installed very easily by using simple jointing tools.

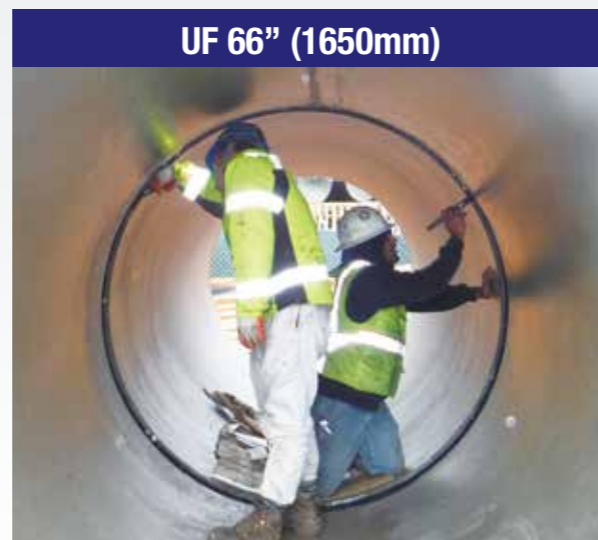

# ERDIP for Pipe-in-Pipe / Casing method installation

ERDIP is also available for pipe-in-pipe / casing method installation in the range of 12"(300mm) to 60"(1500mm), insert new ERDIP into the existing / casing pipes by trenchless method. For detail, please contact us.

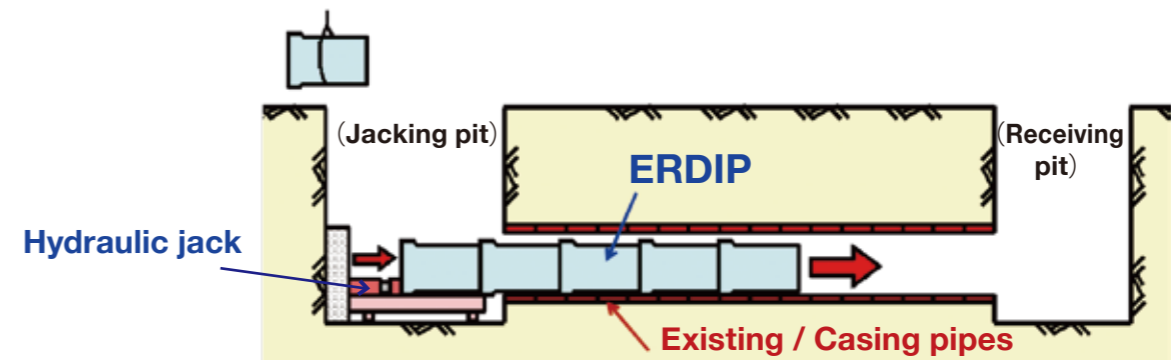

# Share of ERDIP in Japan

The amount of installed ERDIP has increased drastically in Japan after the 1995 Kobe Earthquake.

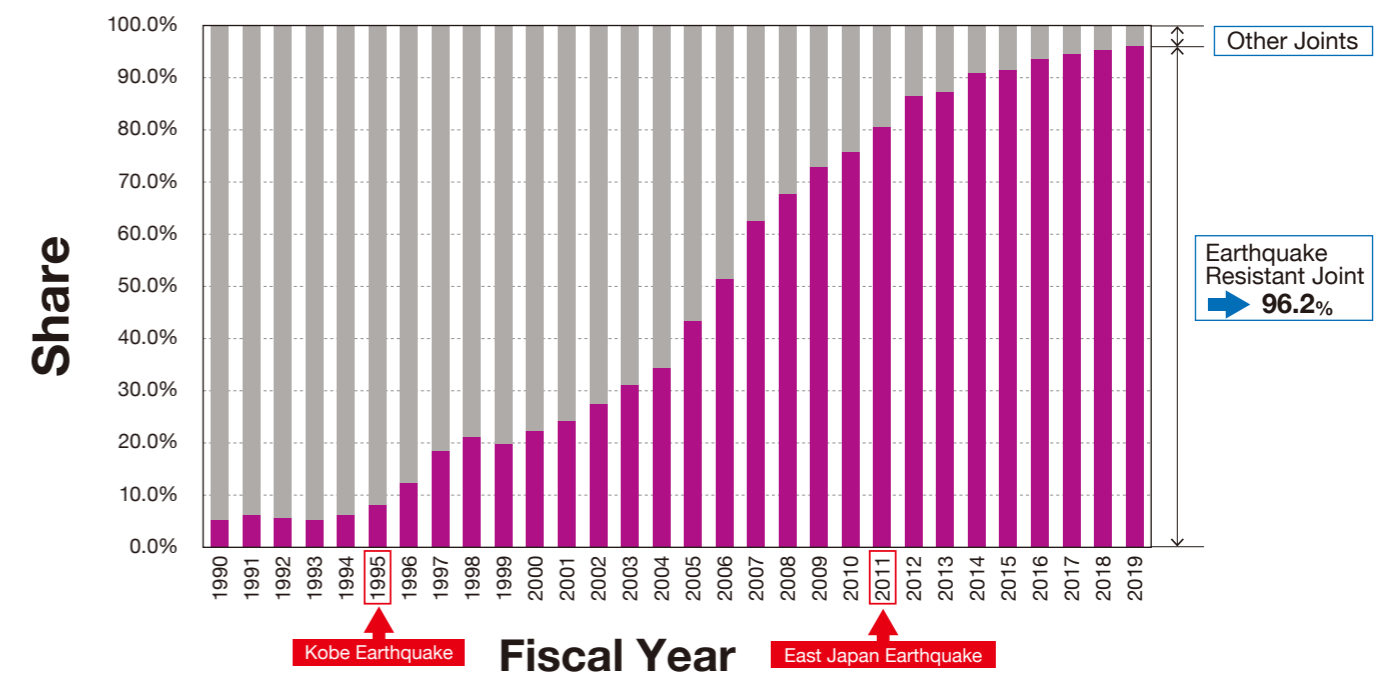

$$\text{Share} = \frac{\text{Earthquake Resistant DIP shipment (in length)}}{\text{All DIP shipment}}$$

Source: Japan Ductile Iron Pipe Association