

KUBOTA TECHNICAL REPORT (EXCERPT)

Feature Theme

Kubota Group Aiming to Find Solutions to Challenges in Food,
Water & Environmental Fields Through Global R&D



KUBOTA TECHNICAL REPORT (EXCERPT)

No.50 JANUARY 2017

CONTENTS

[Feature Theme]

Kubota Group Aiming to Find Solutions to Challenges in Food,Water & Environmental Fields Through Global R&D

Prefatory Note

**Kubota –Contributing to the Lives of People Around the World
Through Technology, Products and Services** 3

Feature Text

Development of MU5501, Multi-purpose Tractor for Indian Market 4
Development of Engine System Diagnostic Tool for Global Service 11
Development of Corn Harvester PRO1408Y with Husking Function for China 17
Development of New Power Tiller for Emerging Markets 24
Development of “Non-Stop Baler” Technology 30
Development of Z700 Commercial Zero-Turn Mower 36
Development of Riding Type Rice Transplanter SPV for Overseas 42
IoT Solution System of Water Environment Infrastructure Facilities: KSIS 48
Development of Submersible Sewage Motor Pump for China (KS-J Type) 55

Feature Technical Report

Development of Strategic Backhoe for China 61
Installation and Operation of Solid-Liquid Separation System for Al Ansab Sewage Treatment Plant in Oman 63

Special Issue Introduction Article

The Introduction of Kubota Research & Development Asia (KRDA) 68
Establishment of Kubota Water and Environment R&D Center USA 71

Kubota – Contributing to the Lives of People Around the World Through Technology, Products and Services

President and
Representative Director
Masatoshi Kimata



The year 2016 was one in which society was greatly affected in all areas of politics, economics, nature, and the environment. Communication networks such as the Internet have developed, and it is now possible for information on the above areas to spread to places all over the world, largely reducing the distances between countries. On the other hand, people around the globe are living in their respective regions, and while they are searching for joy and happiness in their lives it is not easy to determine the true needs of their regions. Kubota is considering how to achieve this and contribute to the world, with the keywords of Priority Onsite and Customer-First Principle.

Kubota has contributed to society for over 120 years in Japan's food, water and environment fields through technology and products. In recent years, we have been operating as a global company that has bases of production and development all over the world. Keeping in close contact with each region, we listen to customers' opinions, and enhance technology to solve their problems, develop such technology into products and services, and propose them.

However, Kubota's goal is not limited to just solving customers' problems. We want to be a company that provides technologies, products and services that let customers feel new pleasure and excitement. By doing this, we believe that we will be trusted by the largest number of customers and make the most contribution to society. This is the global major brand that Kubota is aiming to become.

A global major brand is a company that can create new value not found elsewhere in the world. To achieve that, the most important task is research and development.

Kubota's engineers are working hard on field-based development in Japan and the world, having

discussions with each other, thinking, acting, increasing the level of their own detailed knowledge and learning new technologies. Creating new value leads to greater wisdom and growth of oneself. Our engineers always seek to satisfy customers with products that have a new value, backed up by novel technology. They also plan products, formulate development plans, and conduct research, development, testing and evaluation activities in an untiring manner.

We have given this Kubota Technical Report No. 50 the special theme of "Kubota Group Aiming to Find Solutions to Challenges in Food, Water & Environmental Fields Through Global R&D." Out of the world's population of 7.3 billion people, a large number live in emerging countries, including the 1.4 billion people in China and the 1.3 billion in India. And they face many issues related to food, water and the environment. These issues are not limited to emerging countries but are also global ones that exist in developed countries as well. As feature text, we have published examples of our developed products that can help to solve these problems in emerging countries such as China, India, and Thailand, and also in Europe and North America. In addition, we have posted articles on our efforts related to products and services for the global market such as the following: an engine system diagnostic tool that is distributed over the Internet, technology that applies the IoT to manage water treatment facilities, the state of our development of construction machinery in China, the situation regarding our installation of water treatment facilities in the Middle East, and development bases that we have newly established overseas. Please read through these articles and see how Kubota is growing globally.

Development of MU5501, Multi-purpose Tractor for Indian Market

Tractor Engineering Dept./Farm & Industrial Machinery R&D Dept. III /Vehicle Base Technology Engineering Dept.

India has the world's largest tractor market with a demand of 600,000 units per year. Due to its low tractor penetration rate, further growth of the Indian market is expected. Kubota needs to launch full-scale operations in the world's largest market, India, in order to become a major global brand that can contribute the most to society by being trusted by the largest number of customers. Therefore, we have developed the heavyweight tractor MU5501 suited for Indian multi-purpose uses including high traction. We have frequently visited Indian market and have conducted market-

oriented development with different concepts from those of the previous lightweight and compact Kubota tractors. Here we show the characteristic way of operating a tractor in the Indian market and how to meet market demand for products with low fuel consumption and high durability.

【Key Word】

Multi-purpose, Market-oriented Development, High Traction, Low Fuel Consumption, High Durability, Strength Analysis

1. Introduction

Tractors play important roles in agriculture, and 600,000 vehicles, which is more than a third of the 1.7 million that are sold around the globe each year, are sold in India (Fig. 1). On the other hand, the number of tractors used per unit area (ha) in India is 16.7, which is smaller than the global average of 19¹⁾, indicating that India is the world's largest market for tractors and more growth is expected there in the future.

In addition, the percentage of India's GDP that is accounted for by the agricultural sector is 14%, which is relatively small compared with the service industry and mining and manufacturing industry²⁾, while 58% of the working population works in agriculture. To help India develop further, the challenges are to improve agricultural productivity and increase the incomes of those working in agriculture. One of the solutions to these issues is to promote the mechanization of agriculture.

In 2010, Kubota therefore introduced its tractors which had contributed to the mechanization of

rice paddy markets in Japan and Asia-with 4WD, lightweight and compact, and high power being the strengths-into the areas of India where rice was cultivated. The compatible markets expanded and sales increased through improvements in specifications after the initial stagnation in business results. However, the sales remained limited. This was caused by the tractors having insufficient weight, which prevented them from functioning well in high traction work such as pulling trailers, which is a common use in India, and dry field farming.

To promote further mechanization of agriculture in India, we must develop heavy-class tractors which are suited to the Indian market and which can impress the customers.

This paper introduces the development of MU5501 (Fig. 2), which may become Kubota's foothold for entering the new markets of dry field farming in India as well as the world, and growing into a major global brand.

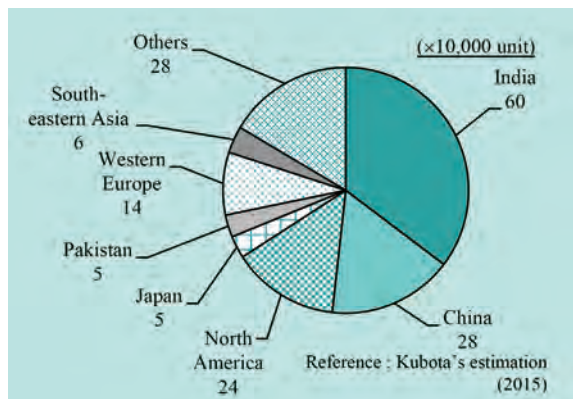

Fig. 1 Annual Sales of Tractors in the World



Fig. 2 Appearance of MU5501 Tractor

2. Development concept and goals

2-1 Development concept

We had failed to conform sufficiently to the Indian market even after improving specifications while using the machines developed with our conventional concept of lightweight and compactness as the foundation. Therefore, we tried to develop a new model with flexibility instead of slightly changing the existing model so that it would match the Indian market. We implemented a market survey for the entire country of India with the focus on the high-priority regions and solidified the development concept with importance placed on user needs. As benchmarks, we selected [1] Company A which was a local manufacturer with the top share and [2] Company B which was a foreign manufacturer. While Company A had a good reputation for low price and low fuel consumption, the customers were dissatisfied with durability, including frequent oil leak from the vehicle body. On the other hand, Company B had a good reputation for performance and durability, but there was dissatisfaction with its products' high fuel consumption.

Joined by the local engineering and sales staff, we discussed the market evaluation of the above competitors that we set as benchmarks, their product specifications and the market demands for service. We also talked about measures to meet the demands. We determined to set the final development concept as a "multi-purpose tractor suitable for the Indian market where basic performance is considered important."

A multi-purpose tractor in India is one that performs various functions without rest throughout the year, including traction work on dry fields, rice

paddy puddling, and harvesting with a tractor-mounted combine in which the tractor is used as the source of power (Fig. 3) during the busy farming seasons, and transporting using a trailer during the off-seasons (Fig. 4).

With the presumption that it would be a heavy-class tractor capable of multi-purpose work, we set up the following items as important development goals:

- [1] Low fuel consumption
 - Improvement in user profit through reduction of running cost
- [2] High durability
 - Improvement in user profit through reduction of downtime as the tractor is used throughout the year
- [3] High operability and comfort
 - Improvement in work efficiency suited to long hours of use, and reduction in accumulation of fatigue
- [4] Adoption of parts purchased in India
 - Cost reduction and improvement in availability of spare parts

We believe the most important development goals are compatibility of low fuel consumption and high durability, which has not been addressed by the competitors among the items above, as well as adoption of parts purchased in India, which can help address [1] to [3].

This paper introduces our efforts in achieving low fuel consumption, high durability and adoption of parts purchased in India, among the above development goals.



Fig. 3 Harvesting with Tractor-mounted Combine



Fig. 4 Transporting of Sugarcane Using Trailer

2-2 Development goals

(1) Low fuel consumption

As described previously, there are areas in the Indian market where the annual operation period of a 40-kilowatt-class (55 horsepower, the power of MU5501) tractor exceeds 1,200 hours as it is used in work without rest for multiple purposes throughout the year. Furthermore, in India, the low labor cost compared with the nearly universal fuel cost over the world makes the fuel cost relatively higher. Low fuel consumption is therefore strongly demanded in the Indian market in order to reduce the running cost.

We thus set up a goal of having fuel consumption equivalent to that of Company A with a good reputation for low fuel consumption, which also corresponded to a 10% reduction compared with the level of Company B.

(2) High durability

To improve farmers' income by increasing productivity and allowing for long-period operation of the tractor, it is important that the downtime caused by failures is minimized. It is

also possible to help tractors work for longer by extending the service intervals for consumable parts.

We therefore set up the goal of having a durability of basic parts equivalent to that of Company B which had a good reputation in the market, and higher than that of Company B for important functional parts such as the clutch.

(3) Adoption of parts purchased in India

Although India has subsidy systems (varying by state, but approximately 20 to 30% of the purchase price) provided by the government or civilian organizations, 85% of the users still purchase tractors with a loan, indicating that they are expensive. It is also important that the parts are readily available as such availability is directly connected to downtime reduction.

We therefore set the goal of having 60% as the rate of parts purchased in India based on the price, except for the engine, in order to reduce the cost and improve the availability of spare parts.

3. Technical issues to be solved

The technical issues in this development are described below:

(1) Optimal traveling speeds setting for low fuel consumption

Two important items which determine the fuel consumption are the engine and traveling speed and torque suited to the work.

We therefore developed an engine with low fuel consumption while also addressing compatibility with exhaust gas regulations, low vibration and low noise, in cooperation with the Engine Department. We worked to optimize combustion with central assignment of the injection nozzle, increase combustion efficiency with the adoption of four intake and exhaust valves, and reduce frictional resistance by reducing the width of the piston ring. We also strove to reduce fuel consumption per unit power period in g/kWh by 15% versus the conventional model when comparing with single-unit engines.

The challenge was to implement a traveling speed design appropriate for work in India with the 8 speeds, two range gears (L and H) four main gears (1-4). We also had to reach the goals by fully utilizing the characteristics of this low fuel consumption engine.

(2) Ensuring a vehicle body strength with high durability

MU5501, which is a heavy-class tractor, is heavier than other Kubota tractors of equivalent power and higher loads are applied on the vehicle body parts. In addition, people in India use tractors in ways different from those in the markets which Kubota has entered in the past. Typical cases include transporting goods with a fender with a large top board and placing extremely large loads on trailers which is something that is never seen in other countries. Table 1 shows the tractor power and the weight of a trailer being pulled. It shows that a 37-kilowatt-class tractor in India tows the same weight as that which is usually towed by a class exceeding 78 kW in Europe. That is, they have higher loads for the same vehicle rank.

Furthermore, they use tractors in a way that places higher loads on the rear axle or rear axle case by lifting the front wheels in the air when attaching a trailer and applying the entire vehicle weight on the rear wheels so that the maximum traction force can be delivered (Fig. 5).

The challenge was to establish a new evaluation method which reflected such characteristic uses in India.

Table 1 Comparison of Tractor Power and Trailer Weight

Destination	Power (kW)	Trailer weight (kg)
India	26~33	8,000~12,000
	33~37	12,000~20,000
	37~44	20,000~35,000
Europe	55	10,000
	78	12,000
	100	32,000



Fig. 5 Characteristic Traction Method in India

(3) Adoption of parts purchased in India

In order to reduce the cost and improve the availability of parts through purchasing in India, we designed the peripheral parts so that the existing products of the suppliers such as the hydraulic equipment which is a functional part, electrical components, and service parts could be used. We also cultivated new manufacturers for large cast cases and gear shafts which are cost-effective items. This paper describes the purchasing of large cast cases within India.

A case in a tractor does not simply surround the gear shaft, but is an important strength component which receives the work load. It is thus difficult

to determine its shape. Conventionally, the main production shape is determined after conducting an evaluation two or three times using prototype cases if a case is to be manufactured newly. However, there was no such concept as prototyping in India, and our challenge was to determine the mass production shape with only one time evaluation using case prototyped in Japan. This is because large castings required enormous costs in die correction and the Indian manufacturers were not able to manufacture the main production die with a short lead time like we were in Japan.

4. Technologies to solve the issues

4-1 Optimal traveling speeds setting for low fuel consumption

4.1.1 Traveling speed setting

As described previously, the engine mounted in MU5501 we worked to reduce the fuel consumption by 15% in a single unit. We measured the tractor power characteristics so that the characteristics of this engine could be utilized. As a consequence, we confirmed that it had high fuel consumption efficiency in an engine speed range of 1,200 to 2,000 rpm, and that it was useful to set up the working speed so that operation is implemented in this low fuel consumption range. We thus studied the working speed for each type of operation in India. Based on the results, we set up the traveling speeds so that the low fuel consumption range could be selected in multiple traveling speeds in each type of work (Fig. 6). For example, during ploughing, work is done in the low fuel consumption range of the L-3 gear when the load is heavy and high torque is required, and in the low fuel consumption range of the L-4 gear when the load is light and a low torque is sufficient.

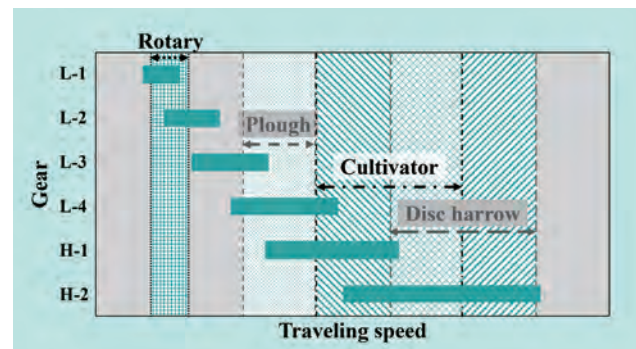

Fig. 6 Working Speed in India and MU5501's Traveling Speed at each Gear at Low Fuel Consumption Engine Revolutions

4.1.2 Verification of fuel consumption using an equi-fuel consumption curve

Final confirmation of fuel consumption was to be done locally in actual, typical work in India. However, we verified the fuel consumption by forming an equi-fuel consumption curve based on the results of tractor power characteristics, because [1] it would be possible to determine the need for further measures to reduce fuel consumption at an early stage and [2] it was practically impossible to verify the fuel consumption in all types of work in all areas of India (Fig. 7).

For example, we estimated the fuel consumption

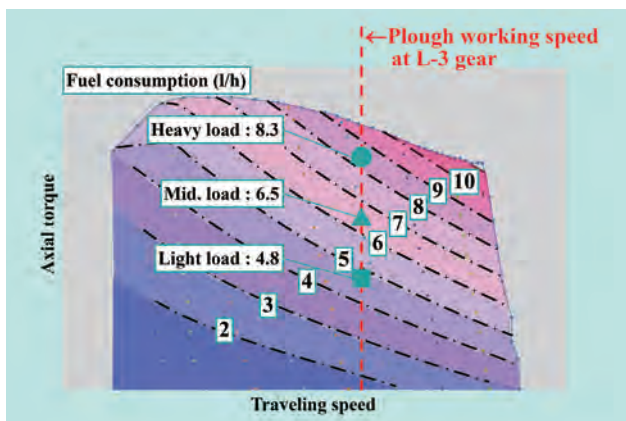

Fig. 7 Fuel Consumption of MU5501

We then took the prototype machine to India and measured fuel consumption in various operations (Table 2). Based on the results, it was confirmed that the fuel consumption goal was achieved even in actual operation. The above processes showed that it was useful to verify fuel consumption in each type of work by utilizing an equi-fuel consumption curve.

under each load level by classifying into three patterns the loads on the vehicle body at each traveling speed during ploughing. We measured the tractor power characteristics for tractors of competitor Companies A and B in a similar fashion, and estimated the fuel consumption under each load to compare with MU5501 (Fig. 8). The results showed the fuel consumption of MU5501 was equivalent to that of Company A and 15% lower than that of Company B, achieving our goal.

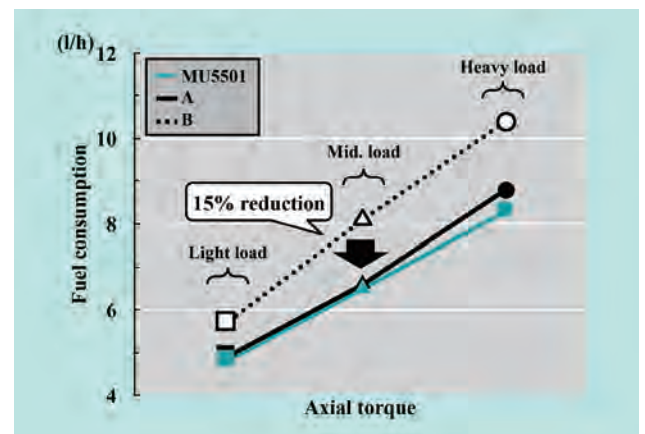

Fig. 8 Comparison of Estimated Fuel Consumption at Plough Working Speed

Table 2 Comparison of Measured Fuel Consumption in each Operation in India (%)

Operation	MU5501	A	B
Plough	100	100	135
Cultivator	100	125	155
Disc harrow	100	85	150
Trailer	100	105	110

4-2 Ensuring a vehicle body strength with high durability

4.2.1 Bench tests to ensure the gear shaft durability

We conducted various durability evaluations and tests reflecting the types of use in the Indian market. The tests were performed on wide fenders, the rear axle oil seal, clutch disk and so forth. This section describes the establishment of endurance test conditions for the gear shaft.

In tractor development, the durability of the gear shaft is evaluated in bench tests simulating loads

under actual operation. However, the loads under actual operation were unknown for the Indian market, and thus it was impossible to evaluate the shaft using the existing test conditions. We therefore took the prototype machine to India and measured operation loads so that the endurance test conditions such as load and number of times could be determined.

4.2.2 Measurement of operation loads in Indian field

We measured the operation loads under various types of work on site, including trailer transport, ploughing and cultivation. The load applied to the gear shaft can be evaluated based on the axial torque and the frequency of its generation during work. Figure 9 shows the results of axial torque measurement during trailer transport work.

It shows that the peak torque was generated when the tractor was started with the H-1 gear. Since it was a load mode we had never experienced before in markets where we had introduced tractors, we added a bench test as a special test item for India. This bench test is simulating the impact load at the start of traveling with the gear for a trailer start. We also set the bench test load to a higher value than conventional corresponding to high traction based on the result of the axial torque measurement during plough traction work.

The gear shaft durability for MU5501 was ensured through the bench test loads which were set up to suit the Indian market as shown above.

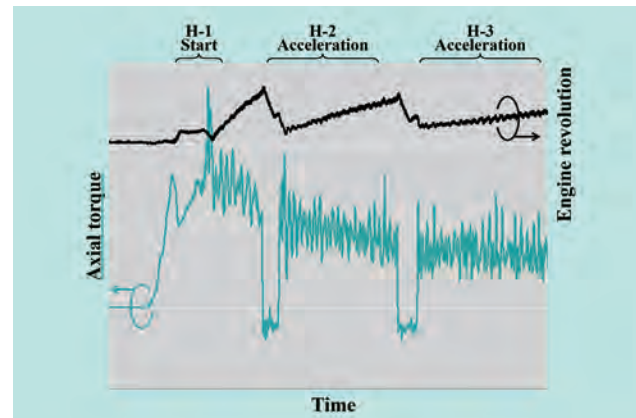

Fig. 9 Axial Torque and Engine Revolution during Trailer Traction in India

4-3 Adoption of parts purchased in India through the utilization of strength analysis

4.3.1 Case stress measurement in various tests

In conventional tractor development, the shape of the case, which is an important strength component, had been determined after repeating multiple times the cycle of [1] prototyping and [2] stress measurements in various work types and evaluation under endurance tests in an actual vehicle. To shorten the development period, we determined the mass production shape through only strength analysis reproducing the load modes in actual operation and in endurance tests.

There have been instances where strength analysis has been performed on multiple cases in an assembled condition close to the actual product in past development. However, this was a new attempt, as we also had to estimate the inertial force of trailer, separately moving with tractor, in addition to the conventional analysis conditions.

To estimate the actual loads into the analysis model, we measured the stress and acceleration simultaneously in addition to the conventional measurement points. Figure 10 shows one of the

endurance test modes, which was a trailer rocket start. While the wheels spin with the rear tires deflection under the trailer load, the front tires are nearly lifted off the ground. We took measurements of data on various other types of work including endurance test modes in order to integrate the actual loads into the analysis model.



Fig. 10 Trailer Rocket Start

4.3.2 Feedback to analysis and integration

We fed back the stress measurement results, described above, to the analysis for each work type, and fixed the constraints and load conditions to conform the actual operation load mode to analysis (Fig. 11).

We then changed the case shape to one in which stress concentration did not occur in any work by using the actual operation load mode in analysis, and go into mass production in India. Then we conducted stress measurement and endurance tests on an actual vehicle using the case manufactured in India. We were able to confirm that there was no problem in terms of strength and demonstrate the usefulness of

this strength analysis method.

As we purchased various parts including the large cast case with high cost effectiveness, gear shaft, and fender in India, and ensured their performance as well as durability, we achieved a local purchase rate of 70%, exceeding our goal of 60%. As a consequence, the period from ordering a part until it was delivered was reduced dramatically for MU5501 compared with the existing models, most of whose components were manufactured in Japan. We thus were able to improve the availability of spare parts and facilitate inventory management at the dealer or parts center.

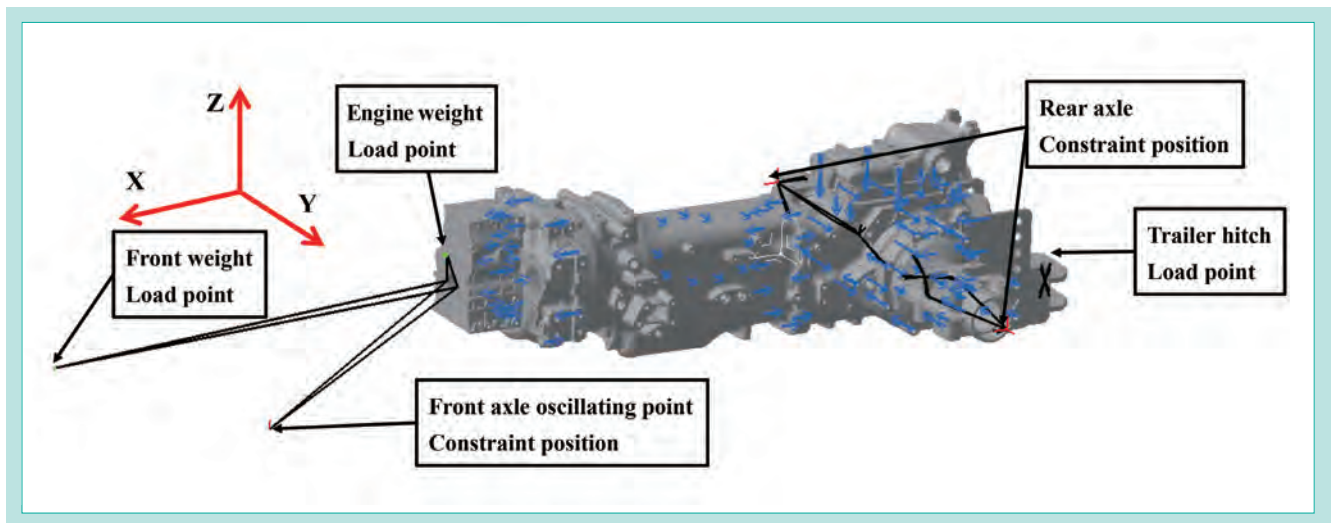

Fig. 11 Analysis Model with Constraints and Load Condition: Trailer Rocket Start

5. Conclusion

We developed MU5501 to promote further mechanization of agriculture in the Indian market, which has the largest tractor sales in the world, and where further development of agriculture is demanded. Through market-in development, we ensured the quality of a heavy-class tractor which could handle multiple purposes in India such as dry field operation and high traction, which were different from the conventional characteristics of being lightweight and compact for Kubota tractors.

In addition to the measures introduced in this paper, we took the prototype machine to various locations in India to have an experienced operator in the region compare it with the benchmarked machines of other companies. We then reflected the evaluation in our development and worked to achieve our development

goals. Then we examined endurance in an actual operation done by local operators to confirm that there was no problem with the evaluation method introduced in this paper.

As a consequence of such promotion of market-in development tied closely with the site, we consider that we were able to create a foundation of trust with Indian customers with a total solution incorporating products, technologies and services. MU5501, which was released in November 2015, will meet customers' demands for quality improvement and further increase its market suitability.

In the future, we plan to actively enter dry field markets of emerging nations in Asia, Central and South America and so forth using the model of this development as the foundation.

Literature

- 1) Japan External Trade Organization (JETRO): Agricultural Machinery Industry of India - Market Investigation Report (from New Delhi), (March 2012)
<https://www.jetro.go.jp>
- 2) The Ministry of Agriculture, Forestry and Fisheries: Report on Fiscal 2011 Overseas Agricultural Information Investigation and Analysis Project (Asia), (March 2012)
<http://www.maff.go.jp>

Development of Engine System Diagnostic Tool for Global Service

Engine Engineering Dept./Engine Environmental Management & Promotion Dept.

These days, industrial engines are becoming more and more dependent on electronic control systems due to strict emissions regulations.

The functions of electronic control devices differ depending on the level of emissions regulations and engine series. With an increase in the types of such devices, the number of diagnostic tools has increased.

And although updating software to control engines through an Internet connection on-site is useful, it has been difficult to achieve this for security reasons.

In this development, various electronic control systems were easily serviced with one integrated diagnostic tool. In addition, a high level of security has been introduced to encourage users to promptly update software over the Internet in the market for small industrial engines.

【Key Word】

Integrated Diagnosis of Engine, Security, Internet Utilization, Market Services, Electronic Controlled Engine

1. Introduction

Kubota engines are used all over the world as they are adopted not only in Kubota's own agricultural machinery and construction machinery but also as OEMs for many different manufacturers of industrial machinery. To respond to various customer demands while also meeting the emissions regulations of each region, the number of models and annual production quantity keep rising.

The range of electronic control is rapidly increasing for industrial engines because emissions regulations are becoming stricter. This has resulted in more tools being needed to diagnose and service the electronic controls (of engines and systems), leading to the fear that it may be impossible to utilize the controls properly unless the

user has advanced knowledge.

Furthermore, electronic controlled engines, which require adjustments to be made to suit each machine, have unique parameters written in the electronic control unit (ECU) of each unit. The ECU controls the engine and has one-to-one correspondence with the individual engine. Instant measures are necessary to deal with customer demands for services over the world for engines that are individually unique.

This paper introduces the technology we have established through the development of Engine System Diagnostic Tool, a product that solved these issues and made a global diagnostic service possible.

2. Development concept and goals

2-1 Development concept

Engine System Diagnostic Tool, which enables a global diagnostic service for the Kubota engines equipped in various machines all over the world (Fig. 1), had the following two development concepts:

- (1) Diagnostic tool which can be used simply with no confusion once connected
The user shall be able to conduct an appropriate diagnostic service without being aware of the subject of diagnosis.

- (2) Instant support anywhere in the world for each unique engine

A quick diagnostic service shall be possible for each of the electronic controlled engines whose models and production quantities continue to increase and which are individually unique anywhere in the world.

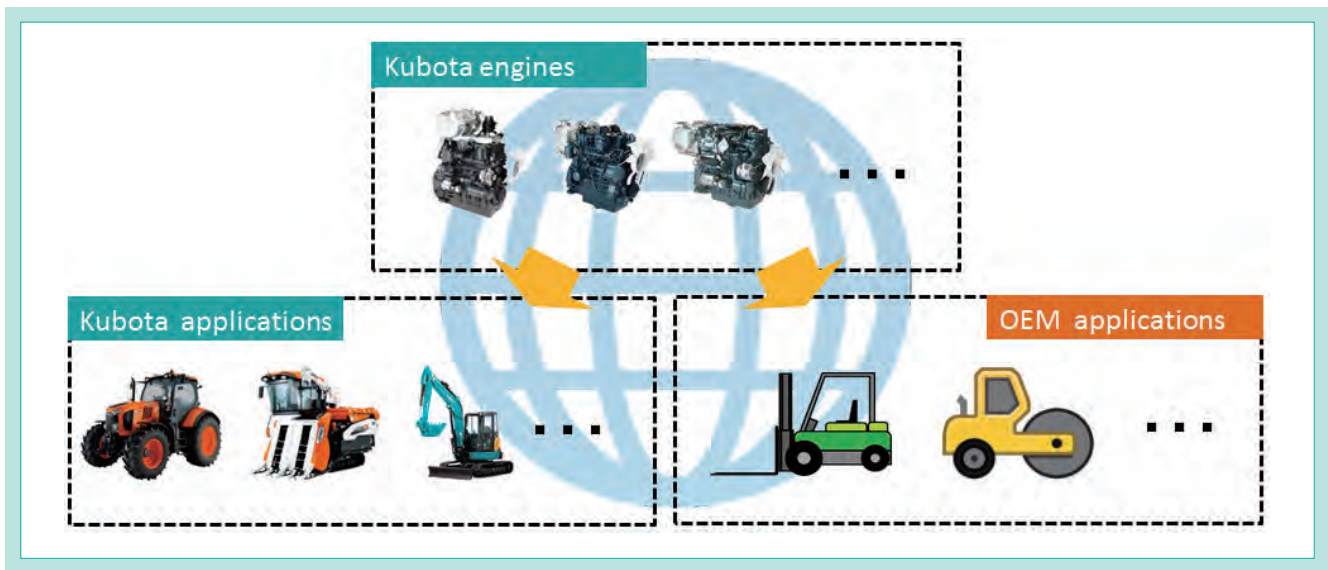

Fig. 1 Applications

2-2 Development goals

- (1) Electronic control of various products (engines and systems) shall be properly serviced with one user-friendly diagnostic tool without the user having to identify the subject of diagnosis.

- (2) Market services shall be sped up by using the Internet to distribute engine control software programs and engine parameters.

3. Technical issues to be solved

- (1) Having an automatic determination function and automatic switching function which allow the user to use various diagnostic service functions provided individually for different engine series, types of control devices such as Common Rail System (CRS), and destinations (internal equipment, OEMs) properly without switching the functions to suit each diagnosis subject.

- (2) Having security functions that can use the Internet to distribute engine control software programs and engine parameters.

4. Developed technology

4-1 Outline of the Diagnostic Tool and data management

4.1.1 Functions of the Diagnostic Tool

The main functions of the Diagnostic Tool are as follows:

- Engine operation monitor
- Failure diagnosis
- Access to failure history and service history
- Changes of service parameters
- Device operation check test
- Control software update

4.1.2 Overall configuration of the diagnostic system for using this Diagnostic Tool

Figure 2 shows the overall configuration of the diagnostic system.

(1) Diagnostic Tool

It is comprised of a PC and a communication interface which connects the PC and ECU, and incorporates the PC software programs and database for conducting the diagnostic service.

(2) Service Data Server

It stores the database for Diagnostic Tool and engine control software programs, and the user can download these data by connecting to this server via the Internet. This database is encrypted and prevents the user from making any changes to the data.

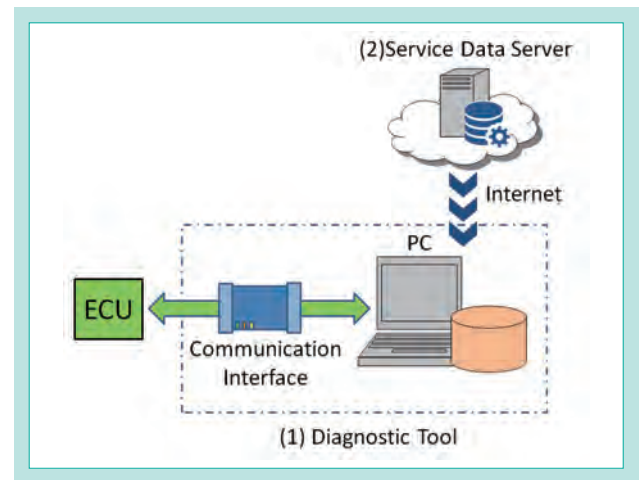

Fig. 2 Overall Structure of Diagnostic System

4.1.3 Information managed by Service Data Server

(1) Database

- Attributes of the service users
Affiliated destination, authorization level, login password, expiration date for use of Diagnostic Tool and so forth
- Attributes of each engine model
Destination, manual information on the machinery on which it is equipped and so forth

- Other necessary management information and so forth
- (2) Data written on ECU
 - Control software for each engine model
 - Engine parameters for each engine unit

4.1.4 Internal data structure for ECU subject to diagnosis

The internal data for an ECU is comprised of the following elements (Fig. 3):

(1) Engine Control Software

Control software program and identification information different for each engine model

(2) Engine Parameter

Engine parameters for each engine unit

(3) Identification Data

Identification information unique to each ECU unit including serial no.

(4) Boot Loader

The basic software program to load the control software.

The ECU on which these pieces of data are written has a one-to-one correspondence with each engine, and conformance to the regulations and quality are ensured only with the proper combination.

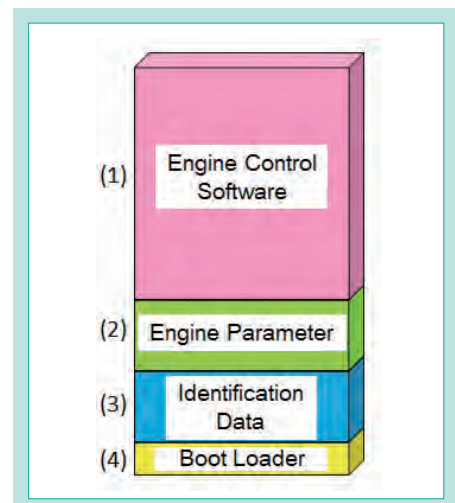

Fig. 3 ECU Internal Data

4-2 Diagnostic Tool which can be used simply by connecting

4.2.1 Automatic determination and switching of the diagnosis subject

Diagnostic Tool sends an inquiry to the database regarding the identification information for each engine model which is read from the ECU. It then automatically determines the series of the engine subjected to diagnosis and its control device to switch to the appropriate diagnostic service functions. The database also has a function to limit the types of engine that can be diagnosed. As shown in Fig. 4, it is possible to comprehensively diagnose an engine with one diagnostic tool, regardless of the

diagnosis subject, and it prevents OEM users from diagnosing engines that have been designed for equipment in Kubota's own machinery.

Table 1 shows an example of engine data monitoring.

As discussed above, the diagnostic service functions can be automatically switched depending on the engine subjected to diagnosis.

These functions allow the user to receive an appropriate diagnostic service without identifying the subject of diagnosis.

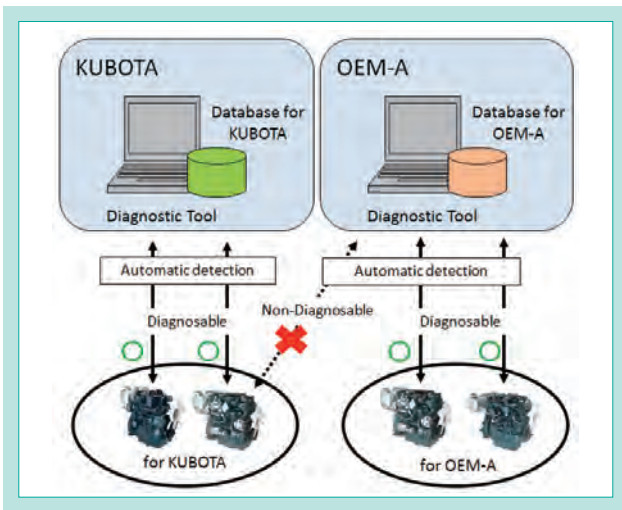

Fig. 4 Automatic Detection

4.2.2 Diagnostic service functions for each level of user authorization

A user authorization management function is established within Diagnostic Tool to restrict the diagnostic service functions that can be used by each authorization level.

As shown in Table 2, only the necessary functions for each user are displayed, such as only reference to operation data being available and partial change of engine parameters being possible, to suit the role of the user. This makes it possible for the tool to be used without confusion.

Table 1 Function Restriction for Target

	Data Monitoring		
	Device 1	Device 2	Device 3
Engine A	○	○	○
Engine B	○	○	
Engine C	○		

Table 2 Function Restriction for each User

	Data Monitoring	Change of Service Parameters	Control Software Update
User 1 (High Level)	○	○	○
User 2 (Mid Level)	○	○	
User 3 (Low Level)	○		

4.2.3 Simultaneous diagnosis of multiple control units

Conventionally, an engine had been electronically controlled by only one unit of ECU.

However, some recent engines have coordinated control with an additional control unit for the post-processing system besides the ECU, and our diagnostic service cannot be provided properly unless it is capable of simultaneously diagnosing multiple units. We have established and applied

a method which allows one diagnostic tool to communicate simultaneously with both the ECU and the control unit for post-processing system. This has made it possible to obtain information on the operating conditions or failure conditions of each control subject simultaneously and properly diagnose the coordinated control of multiple units.

4-3 Internet distribution of control software programs and so forth

4.3.1 Conventional software update

Since an ECU has a one-to-one relationship with the engine, we used to prepare a replacement ECU in which the same control software program and engine parameters from the shipment of the subject engine had been written at a Kubota plant. We

shipped it if there was an ECU control software update or ECU damage.

Therefore, we had the problem of it taking a long time until it reached the customer.

4.3.2 Software distribution utilizing the Internet

We made it possible to update the control software and prepare the replacement ECU in the market by using the Internet to distribute the engine control software program and engine parameters.

In utilizing the Internet, we have ensured security by introducing a function to verify identification information and encrypted data.

(1) Control software update

The procedures to follow when there is an update of the control software program are as follows (Fig. 5):

- [1] Encrypted data including the corresponding software program and identification information subject to update is downloaded from Service Data Server.
- [2] Diagnostic Tool reads the identification information for the subject ECU and authorizes a software update only when it matches with the identification information subject to update within the encrypted data.
- [3] Diagnostic Tool updates the control software for the ECU and confirms that the data has been correctly written.

(2) Preparation of replacement ECU

We introduced a blank ECU as one of the elements to speed up the measures in case of ECU damage. Figure 6 shows its structure. Unlike the normal internal data structure of an ECU described in Section 4.1.4, only identification data unique to each unit such as the serial no. and Boot Loader are written on the ECU. Measures are sped up by using the blank ECU stocked at the distributor or customer in advance for preparing to replace an ECU in case of ECU damage.

Furthermore, by utilizing this blank ECU commonly for various different engines, the number of replacement ECUs to be managed can be reduced by 90% and it contributes to a reduction of stock in each place.

The procedures to write control software and the engine parameters on a blank ECU are as follows:

- [1] Encrypted data including the same control software program and engine parameters as the subject engine having ECU damage are downloaded from Service Data Server.
- [2] Diagnostic Tool reads the identification

information from the subject blank ECU and compares it with the identification information inside the encrypted data, and writing of the control software and so forth is authorized only when they match.

- [3] Diagnostic Tool writes the control software and engine parameters on the ECU and confirms that writing has been done correctly.

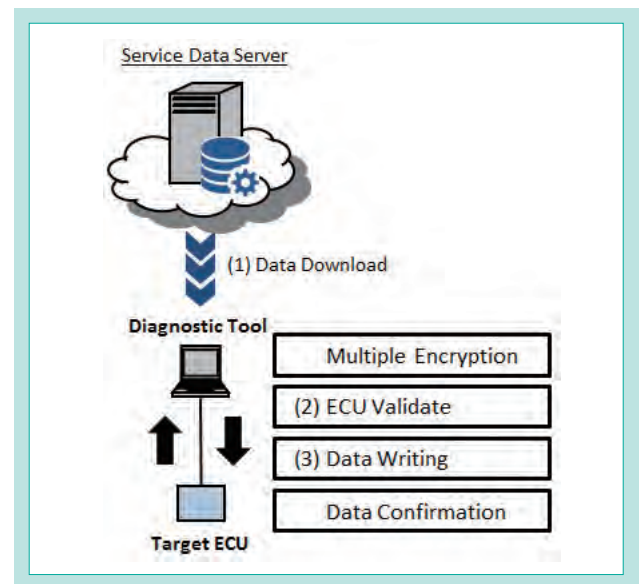

Fig. 5 Delivery of Encrypted Data

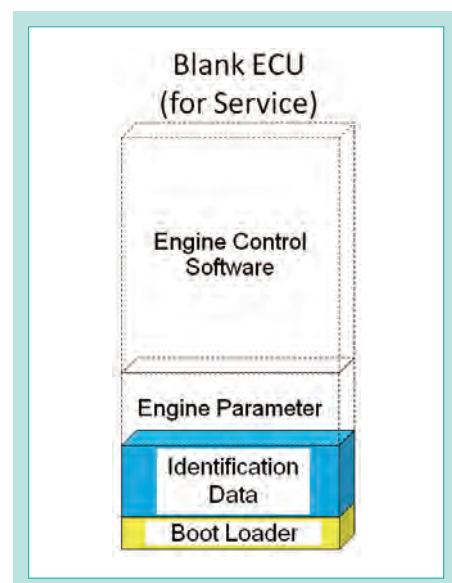

Fig. 6 Blank ECU

(3) Structure of encrypted data

Figure 7 shows part of the internal structure for encrypted data. We super-encrypted ECU verification data, control software and engine parameters with a combination of multiple encryption methods and thus prevented any unauthorized data utilization and data leak.

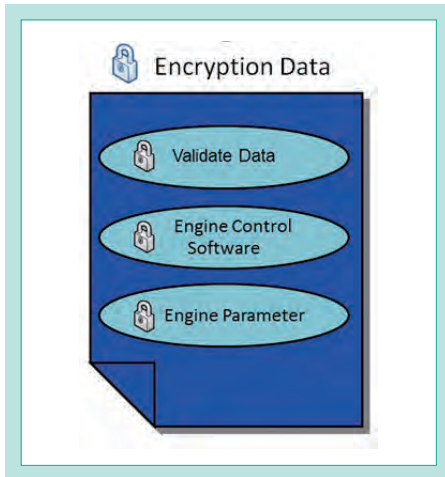

Fig. 7 Encrypted Data Structure

(4) Traceability functions

To grasp and manage the statuses of use of control software updates and downloaded data in market ECUs, we made it possible to collect these statuses via the Internet and verify the control software writing.

Figure 8 shows an example of the traceability screen. We can grasp the situation correctly as it records who wrote which software program on which engine (ECU) and when the writing was done.

Select	Action Date	Software Part No.	ECU Serial No.	User
<input type="checkbox"/>	2013/01/01 12:00:00	XXXXXXXXXXXX	XXXXXXXXXXXX	User1
<input type="checkbox"/>	2013/04/01 15:00:00	□□□□□□□□	□□□□□□□□	User2
<input type="checkbox"/>	2014/07/20 18:00:00	○○○○○○○○	○○○○○○○○	User3
<input type="checkbox"/>	2015/02/21 11:00:00	△△△△△△△△	△△△△△△△△	User4

Below the table are buttons for 'Next', 'Download', and 'Back'.

Fig. 8 Traceability

5. Conclusion

This study aimed to achieve automatic determination and switching functions for a diagnosis subject. They have enabled the user to make a simple diagnosis of an engine without identifying the diagnosis subject. We also made it possible to use the Internet to distribute software while having security functions to prevent unauthorized access.

To improve the share in the global market, it is important to achieve serviceability in addition to having a good performance for the engine main unit.

In the future, we plan to expand and deepen the global diagnostic service we established in this development and help Kubota engines develop into a major global brand.

Literature

- 1) ISO:14230 Road vehicles - Diagnostic systems - Keyword Protocol 2000
- 2) ISO:14229 Road vehicles - Diagnostic systems - Diagnostic services specification
- 3) ISO:15765 Road vehicles - Diagnostic on Controller Area Network (CAN)

Development of Corn Harvester PRO1408Y with Husking Function for China

Kubota Agricultural Machinery (SUZHOU) Co.,Ltd. Engineering Dept./Combine Harvester Engineering Dept.

China is the world's second-largest producer of corn, with 33,540,000 hectares of planted acreage, and a production of about 200,000,000 tons of corn a year. However the rate of mechanization of harvesting work is low at 48 % (2014) and there are expectations that from now on the market for corn harvesters will further expand. In addition, the machines that currently exist in the market and that are made by Chinese local manufacturers have a poor performance and experience many troubles; hence, farmers are requesting high-performance and high-quality machines. Kubota Agricultural Machinery (Suzhou) (hereinafter KAMS) can speedily grasp the market needs and reflect them in

its development. And its Technical Development Department has linked up with Kubota's Harvester Development Department from the design stage and participated in developing work blocks. As a result, we were able to quickly develop PRO1408Y, a corn harvester with a husking function, that meets the market's requests for high-speed work, reduction of yield loss, high husking rate and low-fuel consumption.

【Key Word】

Corn Harvester, High-speed Work, Low Loss of Yield, High Husking Rate, Fuel-efficiency

1. Introduction

In China, demands for meat are growing as people's dietary life is becoming richer in concurrence with the country's economic growth. This is resulting in growing demand for the production of corn, which is used as feed for livestock. The Chinese market for corn has therefore grown to a planted area of 33.54 million hectares and production quantity of approximately 200 million tons, making it the second-largest corn producer in the world. The mechanization of harvesting work for corn in China is also low (Fig. 1) at 48% (2014) compared with rice and wheat, the two other major staple foods in China, indicating that further growth can be expected in the corn harvester market in the future.

However, China has a vast land area, with varying growth conditions for crops among regions and thus varying specifications of corn harvesters that are demanded. We therefore set our development target at the central plains area of the country covering the middle to downstream basins of the Yellow River (Hubei Province, Shandong Province, Shanxi Province, Henan

Province, and Shaanxi Province) (Fig. 2) whose planted acreage of corn corresponds to 43% of the national total.

The mainstream machine used in Europe and the U.S. is one which threshes the corn and harvests the grains. On the other hand, double-cropping of corn, wheat and vegetables is popular in China. In these double-cropping areas, farmers cannot wait until the corn is dry enough for reasons related to the plant's growth period. Instead, they want to harvest while the corn plants are still high in moisture. Since harvesting corn as grains while the moisture content is high results in a large amount of damage, more than 95% of the machines used in China harvest corn as ears. Furthermore, machines equipped with a unit called a "husking part" which removes the husk from the harvested ear obtained the mainstream position in ear-harvesting corn harvesters three years ago. The central plains area we set as the development target was a double-cropping area, and hence we developed an ear-harvesting corn harvester with a husking function.

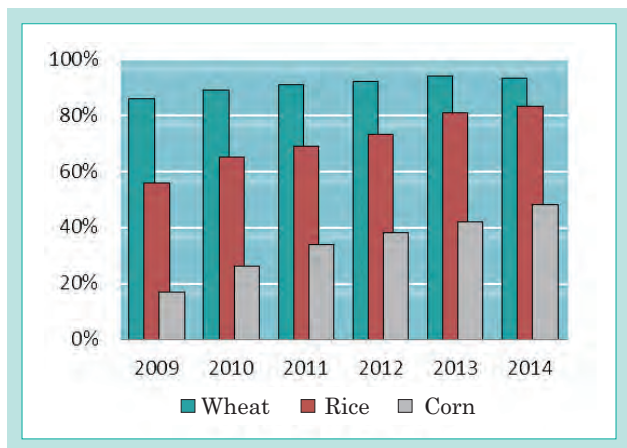

Fig. 1 Mechanization Rate of Harvesters in China



Fig. 2 Central Plains Area

2. Development concept and goals

2-1 Development concept

The current users-Chinese local manufacturers-have small profits due to poor machine performance and frequent troubles.

The central plains area targeted in this development also had characteristics including narrow roads, small fields, and diverse types of interrow space.

Therefore, machines with a short overall length and good turning performance which were capable of handling different types of interrow space without knocking down the stalks were demanded.

That is, the farmers requested a machine with low fuel cost and high profit for the user. If we could develop a compact machine with high performance including low yield loss, high husking rate and high fuel-efficiency that meets the characteristics of the central plains area it would sell well.

To introduce the developed machine into the market in a short period, it was necessary to quickly grasp the performance demanded in market. This could be done by Engineering Department of KAMS

which was close to the market and capable of communicating in the local language.

We therefore decided to develop PRO1408Y, a corn harvester with a husking function which could offer a high-performance and profitable corn harvesting and which matched the characteristics of the central plains area. Cooperative development from the design stage was carried out between the KAMS Engineering Department and Combine Harvester Engineering Dept. of Kubota.

KAMS Engineering Department was in charge of developing the work blocks of the corn harvester (reaping part, feeder part, husking part, selection part, grain tank and chopper) (Fig. 3).

To handle the characteristics of the central plains area, the development concepts for the work blocks with high profit for the user were set up as follows:

- High-speed work
- Low yield loss and high husking rate
- Improved fuel-efficiency



Fig. 3 Work Block of a Corn Harvester

2-2 Development goals

To achieve the above concepts, we set up the development goals as follows. A machine with the highest evaluation in the central plains area with the same engine horsepower range and the number of rows as the developed machine was selected as the benchmark machine.

(1) High-speed work

We would develop a high-performance machine capable of harvesting at a speed 1.3 times that of the benchmark machine. We would focus in particular on improving the processing capacity of the reaping part, which greatly affects the harvesting speed.

(2) Low yield loss

Yield loss would be reduced by 30% from that of the

benchmark machine. We would focus in particular on reducing the loss in the reaping part, where approximately 80% of the yield loss occurred.

(3) High husking rate

We would strive to improve the husking rate by 10% compared with that of the benchmark machine, even for crops with a high moisture content (30 to 35%) which are difficult to husk.

(4) Improved fuel-efficiency

Fuel-efficiency would be improved by 10% compared with the benchmark machine. We would focus in particular on reducing the horsepower consumption of the chopper (the device to chop the stalk after harvesting the corn ear), which took up approximately 50% of the horsepower.

3. Technical issues to be solved

The technical issues to be solved in this development were as follows:

(1) Technical issues related to high-speed work

The processing capacity to remove the ear from the stalk had to be improved in order to harvest at a speed 1.3 times that of the benchmark machine.

(2) Technical issues related to low yield loss

The yield loss in the reaping part occurs mostly as one of the two types described below. These two losses had to be improved.

[1] When an ear came into contact with the side cover of the reaping part, it was separated from the stalk and fell outside the side cover.

[2] Due to the large variety of interrow spaces,

stalks that had yet to be harvested were knocked down by the guide part, resulting in a failure to reap them and causing a loss.

(3) Technical issues related to a high husking rate with crops containing a high level of moisture

The husking part had eight sets of rollers, and the ears had to be distributed uniformly to all of these rollers in order to improve the husking rate. Each ear also had to be introduced to a roller in a parallel position to the roller.

(4) Technical issues related to fuel-efficiency improvement

The horsepower consumption had to be reduced while maintaining the cutting performance at the chopper.

4. Developed technology

4-1 High-speed work

The reaping part has two pairs of rollers called stalk rollers that rotate, and it removes the ear by pulling down the corn stalk as it comes between the rollers (Fig. 4). To achieve high-speed work, the processing capacity of this part had to be improved, and thus we changed the shape of the stalk rollers.

In the beginning stages of development, there were two types of stalk rollers on the market. One was called the "screw type" which had a shape that looked like a round rod was wound around the surface of a cylinder in a spiral. It tended to slip when pulling down the stalk and thus was not suited to high-speed work. However, it had the advantage of having few errors called "broken culm," in which the stalk was also cut when the ear was removed. A stalk with broken culm goes into the grain tank along with the ear. Since it results in the farmer having to separate ears from the stalks, it is better that this occurs rarely. The other was called the "plate type," a part where it looks

like there are six plates attached to the outside of a cylinder (Fig. 5). It had less slipping than the screw type, and was capable of achieving a vehicle speed 1.4 times higher in a test using crops. However, it had the disadvantage of causing the previously described broken culm more frequently than the screw type.

To realize high-speed work, we adopted the plate type for the developed machine. It meant that our great challenge was to improve the broken culm issue (Table 1). We extended the guide plate attached above the stalk roller in the forward direction of the machine body, placing it more forward than the moving part of the stalk roller. In this way, we tried to improve the orientation of the stalk when it entered the stalk roller part so that the level of broken culm occurrence would be equivalent to that of the screw type. We conducted tests by setting the extension lengths to 100, 150 and 200 mm. The results showed that broken culm

was not improved sufficiently with an extension of 100 mm, and an extension of 200 mm caused clogging because there was too much resistance until the crop reached the action part of stalk roller. It turned out that an extension of 150 mm improved the degree of broken culm without any occurrence of clogging. Based on these results, we adopted 150 mm as the length of the extension.

We developed a reaping part which realized a

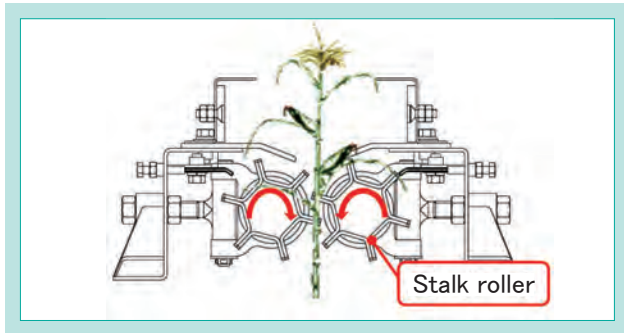

Fig. 4 Structure of Stalk Roller

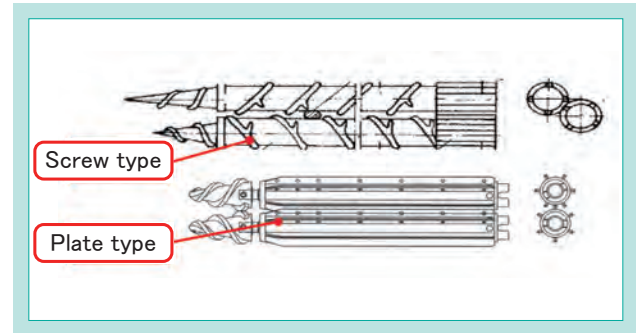

Fig. 5 Comparison of a Screw Ways in Stalk Rollers

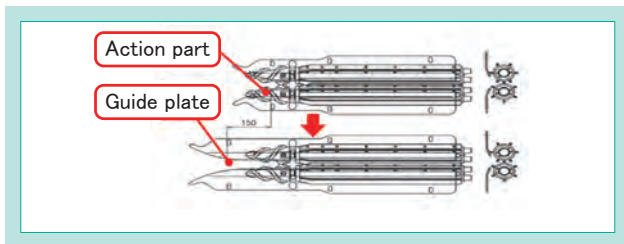

Fig. 6 Change in the Guide Board

Table 1 Comparison of Screws

	Processing capacity	Broken culm
Screw type	△	○
Plate type (benchmark machine)	◎	△
Plate type (developed machine)	◎	○

4-2 Low yield loss

To reduce the yield loss, the two types of losses described in the part on technical issues had to be improved.

4.2.1 Shape of side cover in reaping part (Fig. 7)

The side cover of the reaping part in the benchmark machine was made of metal plate and had a shape in which it was bent into a triangle. The ears would hit the edge of the cover and result in a loss with this structure. Therefore, we gave the developed machine a side cover made of resin with an arc shape so that it was difficult for the ear to fall even when it came into contact with the cover. In addition, by raising the wall by 600 mm from the benchmark machine, we ensured a structure in which the ears would not fall outside the cover, and improved the yield loss (Fig. 8). However, to ensure durability we had to change the material to resin. We therefore conducted indoor acceleration tests by estimating the impact when the ear hit the cover based on damage to the prototype. As a consequence, we confirmed that the durability could be ensured by adopting fibre-reinforced plastic (FRP) as the material and specifying a plate thickness of 6 mm.



Fig. 7 Side Cover of a Developed Machine

4.2.2 Expansion of interrow space flexibility

To develop a machine that could handle the large variety of interrow spaces, parts called "gathering chains" are installed as chains that guide the stalk from the front of the reaping part to the stalk roller. It is ideal if these chains are set so that they are brought to the stalk in a position parallel to the direction of the harvester's forward movement in order to reduce the resistance on the stalk. However, trying to make it parallel (making the angle in Fig. 9 small) would force the tips of the reaping part to be extended and result in a larger overall length of the machine. Since a machine with a minimum overall length was demanded in the central plains area, we utilized the part of the stalk roller made shorter by 100 mm as described previously and reduced the angle from 60 degrees in the benchmark machine to 45 degrees while maintaining the overall length. As a consequence, we were able to reduce resistance and therefore the loss caused by knocking down the stalk when it came into contact with the chain.

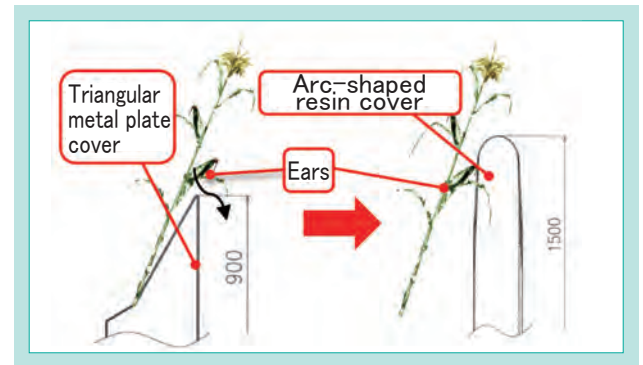

Fig. 8 Benchmark and Developed Machine

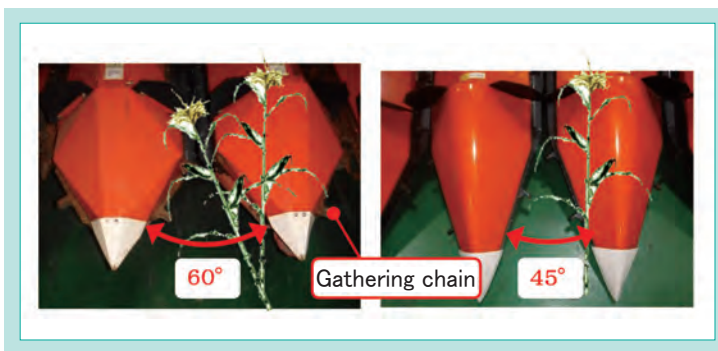

Fig. 9 Comparison of a Benchmark Machine and Developed Machine

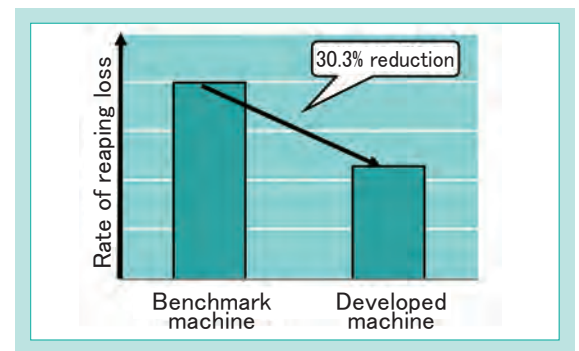

Fig. 10 Comparison of Yield Loss Rate at the Reaping Part

Reduction in the two types of yield loss described previously has resulted in decreasing loss by 30.3% as shown in Fig. 10.

4-3 High husking rate

The husking part removes the husks by rotating two pairs of rollers on opposite sides. As described previously, corn is reaped while it contains a high level of moisture in China. It was therefore necessary to achieve a good ear distribution and

improve the ear's position when entering the machine in order to improve the husking rate for corn plants with a high moisture content which are difficult to husk.

4.3.1 Ear distribution

The ears of corn harvested in the reaping part are transported to the husking part, which has a width of 1,150 mm, from the feeder part, which has a width of 520 mm (Fig. 11). At the maximum processing speed, ears are supplied at the rate of approximately 40 pieces/second. Having them supplied only to some of the rollers would result in lower husking rates or clogging. It was thus our challenge to effectively utilize the entire width of

the husking part, and we installed plates called "ear-receiving guides" at two points to distribute the ears (Fig. 12). As distribution was insufficient in the beginning of development when there was only one point from which the ears were ejected by the feeder, we installed an ear-receiving guide in an additional point where the ears came falling into the machine and improved the distribution effect.

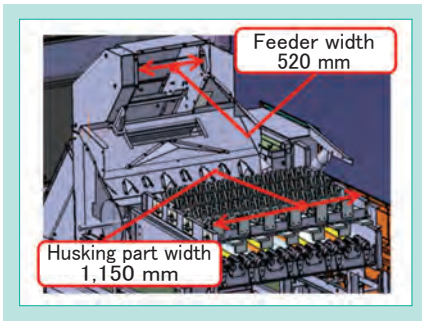

Fig. 11 Width of Feeder and Husking Part

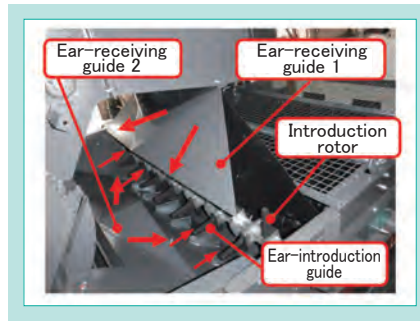

Fig. 12 Dispersion of Receiving Corn Tassels and Posture Improvement Part

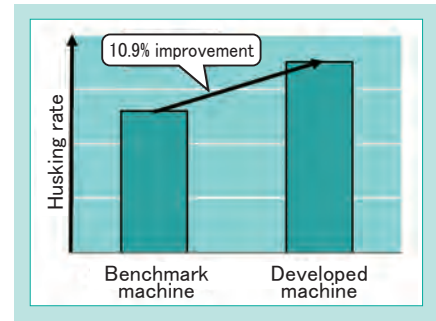

Fig. 13 Comparison of Husking Rates

4.3.2 Ear position

Next, the husking rate is maximized when the ear enters the husking roller in a parallel position to the roller. We therefore installed guide plates called "ear-introduction guides" on eight points. As a consequence, it made sure that ears at angles of 45 degrees and smaller to the rollers were introduced in a parallel position. However, the position could

not be improved for those at angles of 45 degrees and larger. Thus, we introduced another rotating part called an "introduction rotor" so that the ears were supplied to each roller in the parallel position.

These modifications improved the husking rate by 10.9% compared with the benchmark machine with high-moisture crops (Fig. 13).

4-4 Improved fuel-efficiency

The chopper cuts the stalk as a rotary part with cutoff blades rotates. To reduce the horsepower, it was necessary to give the blades a better cutting performance and smaller resistance. Furthermore, to facilitate the tilling work with a tractor after

combine processing, the market wanted the stalks to be cut into short pieces. Therefore, we evaluated the cutting performance by considering the "reaping height," which was the height of the stalk from the ground after it was cut.

4.4.1 New cutoff blade

The chopper cutoff blades of the benchmark machine (Fig. 14) had a structure in which high-hardness metal for wear prevention was welded onto the edge, and thus the cutting part was blunt and low in cutting performance. Machines had to have many blades installed in order to improve the cutting performance. Due to the arrangement of many blades with a large cutting resistance, the resulting horsepower consumption had been large. We therefore adopted the technology owned by another company in Japan for the rotary blades of tractors in our new cutoff blades to achieve development in

a short period. The new cutoff blade has a structure in which the high-hardness material is welded only on the back side of the blade. It is therefore sharper than the structure with high-hardness material welded on the entire blade edge, and it improved the cutting performance dramatically. Since the high-hardness part wears more slowly while the base metal wears down as the machine is used, it has a self-polishing function that constantly maintains a sharp edge, keeping the cutting performance at the same level.

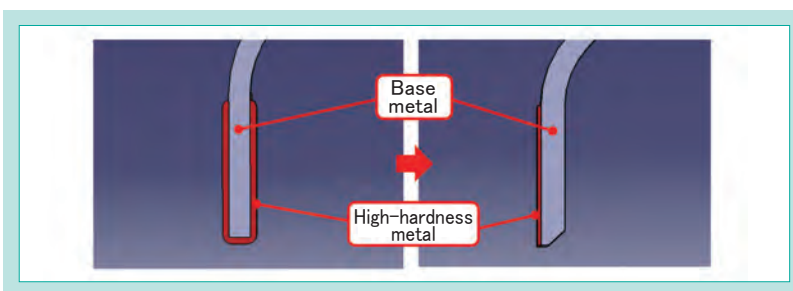

Fig. 14 Comparison of Cutoff Blades

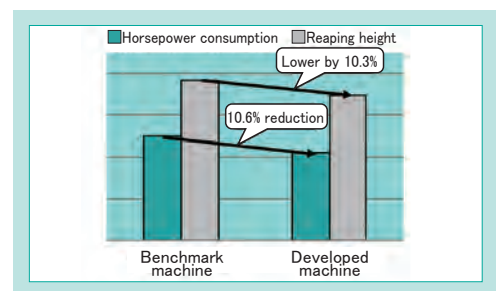

Fig. 15 Chopper Performance Comparison

4.4.2 Layout of cutoff blades

The chopper of the benchmark machine was comprised of 114 cutoff blades in total. Thanks to the adoption of the new cutoff blade, our developed machine delivered a high cutting performance even when the chopper was constructed with 48 blades

in total (Fig. 16). It also improved fuel efficiency by 10.6% while improving the cutting performance by 10.3% compared with the benchmark machine (Fig. 15).

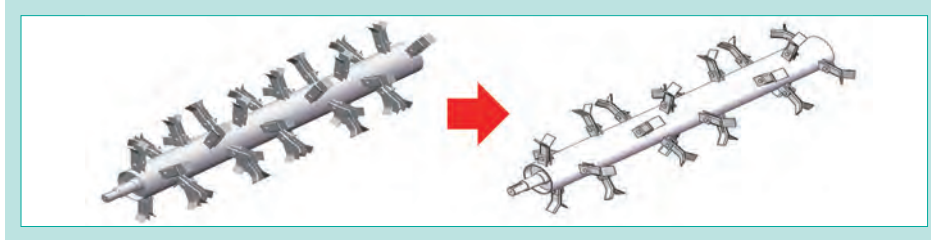

Fig. 16 Comparison of Revolving Blade Layouts

5. Conclusion

We addressed the following items in this development:

- (1) High-speed work
We realized a reaping process at 1.3 times the speed of the benchmark machine with the adoption of "plate-type stalk rollers."
- (2) Technical issues related to low yield loss
We reduced the yield loss by 30% compared with the benchmark machine by changing the side cover of the reaping part to resin, using an arc shape and extending the gathering chains in the forward direction of the machine body.
- (3) High husking rate
With the adoption of ear-receiving guides, ear-introduction guides and an introduction rotor, we improved the husking rate by 10.9% compared with the benchmark machine even for crops with a high moisture content.
- (4) Improved fuel-efficiency

With the adoption of the new cutoff blade, we improved fuel efficiency by 10.6% while also enhancing the cutting performance by 10.3% compared with the benchmark machine.

PRO1408Y contributed to our business expansion starting in 2016 because we were able to have a short period between development and mass production. It was an extremely valuable experience that this collaborative development was implemented between KAMS Engineering Department and the harvester development division of Kubota from the design stage. Utilizing this experience, the four-row machine developed in 2015 was released this year after a short development period for the reaping part and chopper.

Although we only worked on the work block in this development, we plan to raise the development level so that KAMS Engineering Department will be able to develop an entire machine by itself.

Literature

- 1) Report on Development of Chinese Agricultural Machinery Market (2014-2015)

Development of New Power Tiller for Emerging Markets

Kubota Research & Development Asia

World demand for food is increasing along with increasing population. Hence, many emerging countries are starting to mechanize their farm work to increase their crop production capacity so that they can export food and meet that demand. Animals and humans are still the main sources of labor in farm work for most small farmers in emerging countries. This means there is high demand for farm machinery with a good basic performance and multi-purpose functions to help increase the crop production capacity at an affordable price for small farmers. To meet this demand, SIAM

KUBOTA Corporation Co., Ltd. (SKC) developed PEM480, a new power tiller for emerging markets. Not only can it meet the above demand but also it can help SKC to enter emerging markets and establish sales and marketing networks to support future business growth for Kubota.

【Key Word】

Power Tiller, Transmission Efficiency, Gear Tooth Root Fillet Curve Modification, Rotary Tillage, Blade Shaft

1. Introduction

Outline of Business

Power tiller is one of basic farm machines that most farmers use in early period of farm mechanization, or emerging period. In the emerging period, power tiller sales have slow growth because farmers are unfamiliar with its benefits and require time to learn and practice power tiller operation and its benefit to their farm works. Once they become familiar with the power tiller, and its benefit to farm work is widely known and accepted, the annual sales will increase rapidly. Later on farm mechanization will change into the growth period. In the growth period farmers who have experience using power tillers will be ready to step up their farm mechanization level by utilizing higher capacity farm machinery to expand their farm area and crop production. Then tractors will start to emerge into

market in emerging period similar to power tillers. An example of mechanization development pattern is found in Cambodia as shown in Fig. 1.

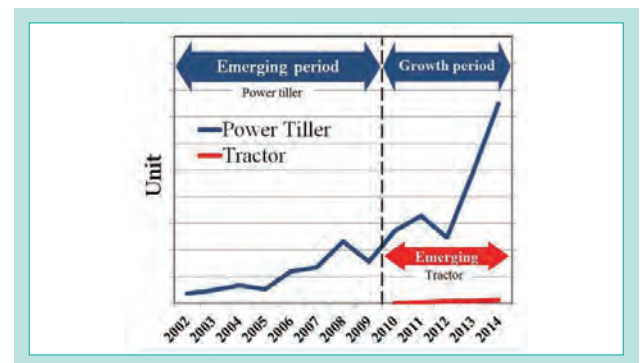

Fig. 1 SKC's Export Sales History to Cambodia

The market survey result for annual demand of Power tillers in some emerging countries is more than 200,000 units (excluding the Chinese market) as shown in Fig. 2.

It shows both of emerging period and growth period of farm mechanization in many countries. For some countries they are still in the emerging period or just starting the growth period, for example Myanmar, Laos, Vietnam, Bangladesh, India and Sri Lanka are still in early period.

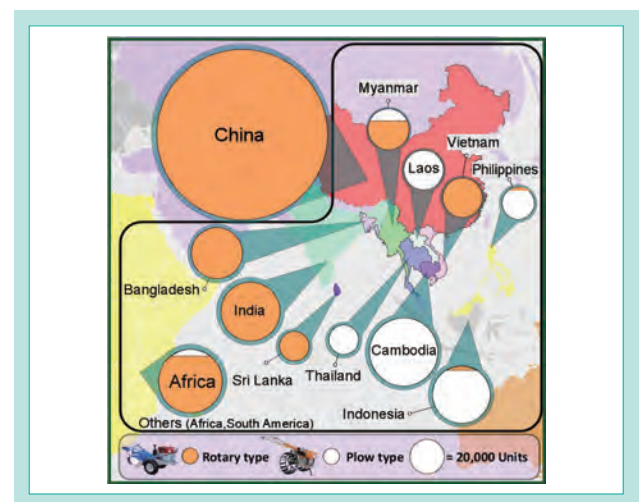

Fig. 2 Estimated Annual Demand for Power Tillers in 2016

2. Development Concept and Target Value

2-1 Development Concept

Power tiller for emerging market model “PEM480” as shown in Fig. 3 was developed with 2 key design concepts, “High performance” (high working capability, high soil incoherent, low fuel consumption, high durability) and “Affordable price” (price that customer can pay).

In order to make these 2 key design concepts

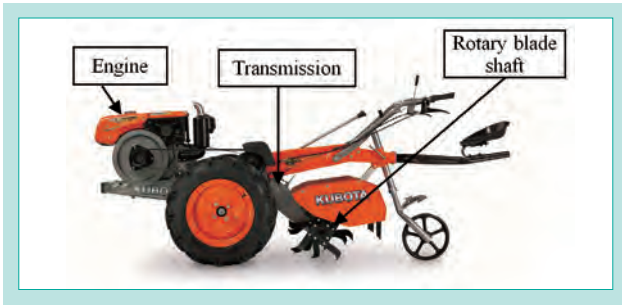

Fig. 3 Overall Structure of PEM480

easier for benchmarking between products in the market, we defined a new single indicator, “Total Performance/Price”. The target for this indicator was set higher than previous model (NC-S) and a benchmark model (A brand) to appeal farmer by both more benefit to their farm work and more value for their investment.



Fig. 4 Overall Structure of NC-S

2-2 Target Value

Although the indicator “Total Performance/Price” is defined, but the target values are divided into many performance related technologies such as 1) high efficiency and compact transmission, 2) optimal performance blade shaft, 3) low-shocked vibration rear wheel suspension system, 4) light-weight integrated belt & flywheel safety cover, 5) light-weight high-traction paddy wheel and 6) high strength single handle frame structure. Due to limited template space in this paper, only “High efficiency and compact transmission” and “Optimal

performance blade shaft” are selected as examples with following target value;

- 1) High efficiency & compact transmission
 - Max. Output Power (P) > NC-S and A brand's
 - Transmission parts weight (m_t) < NC-S and A brand's
 - Max. Efficiency (η_t) > NC-S and A brand's
 - Transmission speeds > NC-S and A brand's
- 2) Optimal performance blade shaft
 - Soil incoherent > NC-S and A brand's

3. Technical challenges to be solved

In order to achieve high efficiency and compactness for power tiller transmission, gear is selected as main transmission component because it provides the highest efficiency among mechanical power transmission components. Therefore the technical challenge is designing a low-cost compact gear with high efficiency but still able to transmitting design power with enough durability.

Due to rotary blade shaft design involve in many design parameters such as blade curve, blade width,

cutting pitch, blade angular arrangement, blade tip radius etc. Defining optimal performance is also related to many performance parameters such as soil incoherent, fuel consumption and working capability. Therefore the technical challenge in the design of optimal performance blade shaft is how to evaluate overall performance of various combinations of blade design parameters to optimize performance blade shaft.

4. Developed Technology

4-1 High efficiency and compact Transmission

To increase total transmission efficiency, we have to reduce total losses (L_t) which are sum of loss (L_{ti}) at each transmission components.

By reviewing recent research, power losses related to gearbox lubricated with oil, there are 4 sources of power loss, gear meshing loss (L_m), gear churning loss (L_{ch}), bearing loss (L_b) and seal loss (L_s). In simple gearbox (2 shafts, 2 gears, 4 bearings and 2 oil seals), power losses related to gear which is sum of L_m and L_{ch} are around 80 % of total power losses.[1]

Considering following gear meshing power loss equation, direction and position of parameters are shown in Fig. 5

$$L_m = P_{in} \cdot H_V \cdot \mu_m \quad (1)$$

P_{in} = Input power

H_V = Load and sliding velocity factor

μ_m = Friction coefficient

$$H_V = \frac{\pi \cdot (u+1)}{z_1 \cdot u \cdot \cos \beta_b} \cdot (1 - \varepsilon_\alpha + \varepsilon_1^2 + \varepsilon_2^2) \quad (2)$$

$$\mu_m = 0.048 \cdot \left(\frac{F_{bt}}{V \Sigma c p_c} \right)^{0.2} \cdot \eta_{oil}^{-0.05} \cdot R_a^{0.25} \cdot X_L \quad (3)$$

$$X_L = \frac{1}{\left(\frac{F_{bt}}{b} \right)^d} \quad (4)$$

and following gear churning power loss equation,

$$L_{ch} = T_{ch} \cdot \omega \quad (5)$$

T_{ch} = Churning torque

ω = gear rotational angular speed

$$T_{ch} = 0.5 \cdot \rho_{oil} \cdot \omega^2 \cdot R_p^3 \cdot S_m \cdot C_m \quad (6)$$

$$S_m = R_p^2 \cdot (2 \cdot \theta - \sin 2\theta) + (2 \cdot R_p \cdot b \cdot \theta) + 2 \cdot \left(\frac{z \cdot \theta \cdot H_{100in} \cdot b}{\pi \cdot \cos \alpha \cdot \cos \beta} \right)$$

$$C_m = 1.366 \cdot \left(\frac{h}{2 R_p} \right)^{0.45} \cdot \left(\frac{V_0}{8 R_p^3} \right)^{0.1} \cdot F_r^{-0.6} \cdot Re_c^{-0.21} \cdot \left(\frac{b}{R_p} \right)^{0.21}$$

$$F_r = \frac{R_p \omega^2}{g}, \quad Re_c = \frac{R_p \cdot b \cdot \omega}{\nu} \quad (7)$$

S_m = Immersed surface, C_m = Drag coef.

R_p = Pitch radius of gear

In order to achieve high efficiency and compact transmission while keeping stress at transmission

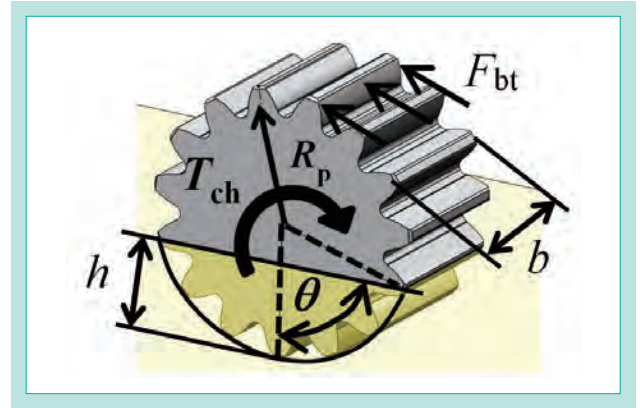

Fig. 5 Parameters Related to Power Loss

From all these equations, if we consider only gear design related variables which are number of teeth (z_1), pitch radius (R_p) and tooth width (b), we can find following relations,

- 1.Reducing number of teeth (z_1) increases meshing power loss (L_m).
- 2.Reducing pitch radius (R_p) reduces churning power loss (L_{ch}).
- 3.Reducing tooth width (b) increases meshing power loss but reduces churning power loss.

For relation 1 and 2 above at fixed transferring torque, reducing number of teeth (z_1) which also reduce pitch radius (R_p) is limited by increasing force on gear tooth (F_{bt}) until tooth root bending stress reach allowable limit or limited by root diameter that must not be smaller than shaft diameter for maintaining the designed shaft strength.

For relation 3, we took one pair of gears in PEM480 into calculation, we found that reducing tooth width (b) is able to reduce sum of meshing power loss and churning power loss but also increase tooth root bending stress.

components in allowable limit, we introduced 2 technical innovations.

4.1.1 Tooth root fillet curve modification

There are 3 parameters related to design of modified root fillet profile: first, Contact ratio (C_r) which defines highest point of root fillet curve when fixed outside radius of considering gear; second, Clearance of dedendum (C_{de}) which defines bottom point of root fillet curve; third, Curve of fillet (C_f) which is defined as curve line starting from highest point (from to C_r) bottom point (from to C_{de}) of root fillet with 3 tangential circular arcs[2] (simplest curve that can be produced by hob cutter).[3] The details of each parameter definition is shown in Fig. 6 and calculated by Eq. (8).

$$C_r = \frac{1}{\pi \cdot m \cdot \cos \alpha} \left[\sqrt{r_{op}^2 - r_{bp}^2} + \sqrt{r_{og}^2 - r_{bg}^2} \right] - \frac{C_d \tan \alpha}{\pi \cdot m} \quad (8)$$

$$r_{bp} = m \cdot z_p / 2, \quad r_{bg} = m \cdot z_g / 2$$

z_p = number of pinion teeth, z_g = number of gear teeth

To find the optimal modified root fillet curve for one pair of gear mesh, we need to find possible design boundary of Contact ratio (C_r) and Clearance of dedendum (C_{de}) as a sample shown in Fig. 7.

By using Finite Element Analysis (FEA) to analyze root bending stress [4] and gear mesh motion analysis to help designing optimal curve of fillet (C_f), the FEA results over design boundary are shown in Fig. 8 and comparison results over std. root fillet curve are shown in Table 1.

Table 1 Tooth Root Fillet Curve Modification Results Compared to Standard Root Fillet

Comparison Scope	Loss reduction	Weight reduction	Cost reduction
Gear train set	5.6 %	15 %	12.5 %

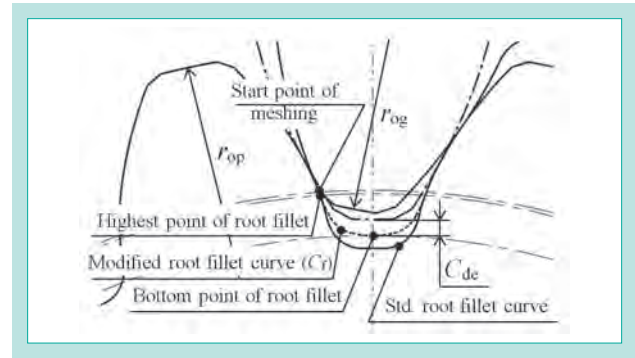

Fig. 6 Definition of Parameters Related to Design of Modified Root Fillet Curve

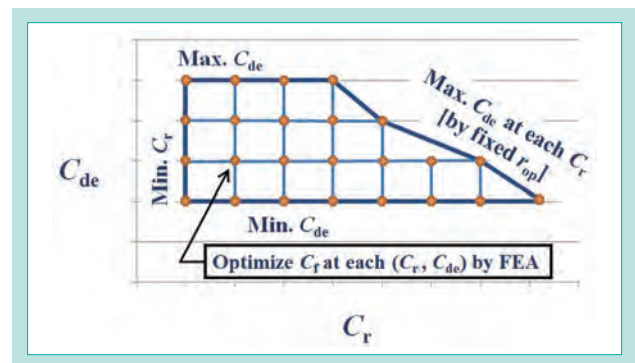

Fig. 7 Design Boundary for Pinion Mesh with Gear Train [Module:3]

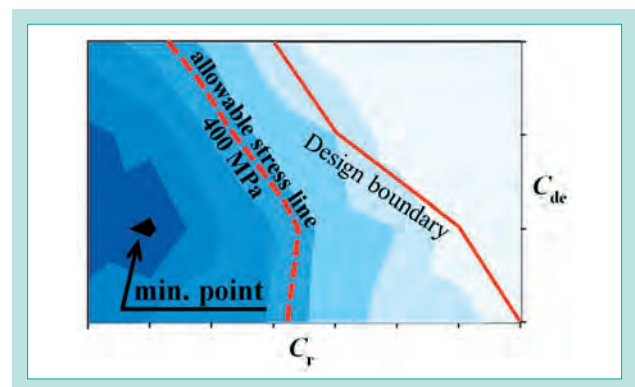

Fig. 8 FEA Results for Root Bending Stress of Pinion

4.1.2 Direct Mounted Center Drive rotary Transmission

If calculating general transmission, the efficiency of gears (e_g) is better than the efficiency of chain (e_c), power loss of both Indirect Mounted Side Drive (I.M.S.D) structure and Direct Mounted Side Drive (D.M.S.D) structure having 2 sprocket-chain drive is

larger than power loss of PEM480 new structure (Direct Mounted Center Drive : D.M.C.D) having only one sprocket-chain drive.

Direct Mounted Center Drive (D.M.C.D) structure shown in Fig. 9 can reduce power losses and weight.

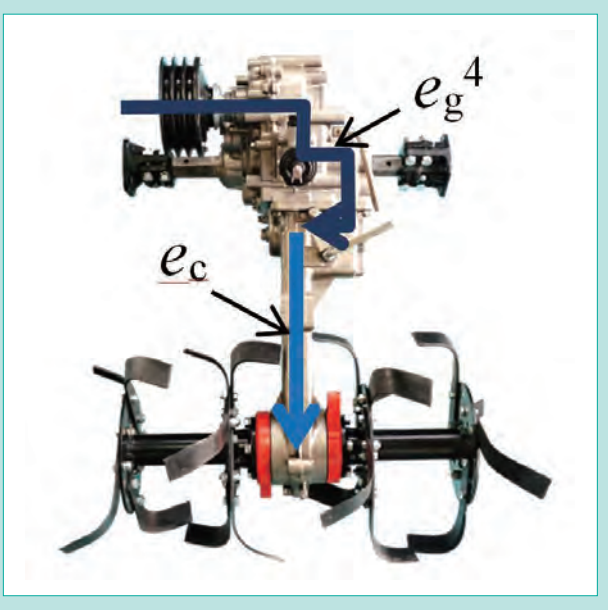

Fig. 9 Direct-Mounted Center Drive Rotary Transmission Structure

4.1.3 Conclusion of High efficiency & Compact transmission

From all design techniques applied above, we can achieved all targets as shown in Table 2.

Table 2 Results of Comparing Transmission Parts

	PEM vs NC-S	PEM vs A brand's
Max. Output power transmitted	>	>
Transmission parts weight	<	<
Max. Efficiency (clutch to blade shaft)	>	>

4-2 Optimal performance blade shaft

4.2.1 Design rotary blade width and pitch

Soil size, theoretically depends on blade cutting width (w), tilling pitch (p) and tilling depth (d). Narrow blade cutting width and short tilling pitch provide small cut soil shape but also need more number of blades per flange (n_i) and blade flanges respectively.

In order to find optimal performance blade shaft, we fix tilling depth (d) as customer requirement and set design matrix between cutting width (w) and total number of blades (N_b) (tilling pitch is directly depended on n_i and N_b).

We do comparison test between various types of blade arrangement in 3 tilling performance parameters (Soil Incoherent [SI], Fuel Consumption [FC] and Working Capability [WC]) and found that the soil size from blade arrangement with single blade per flange at shaft ends is larger than the acceptable size, therefore these types of blade arrangements were not considered.

4.2.2 Conclusion of optimal blade shaft performance

The result of blade shaft in dry sandy – clay soil is shown in Table 3, comparing with NC-S and A brand's performance.

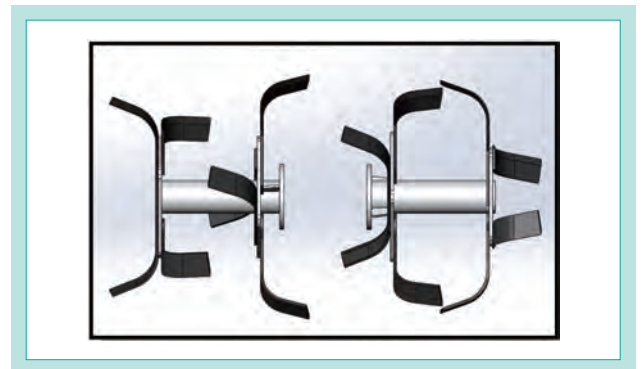

Fig. 10 Rotary Blade Arrangement

The test results of remaining blade arrangement types were evaluated with weight factor (WF) for WC:SI:FE then we found that the blade arrangement type as shown in Fig. 10 gives highest weighted performance score.

Table 3 Soil Incoherent Test Result

Requirement	PEM vs NC-S	PEM vs A brand's
Percentage of Soil incoherent	110 %	125 %

5. Conclusion

5-1 Evaluation of product

With all developed technical innovations PEM480 can meet all targets and much better than NC-S and A brand's as shown in Table 4.

Table 4 Overall Product Evaluation Result

Requirement	PEM480 vs NC-S	PEM vs A brand's
Working capability (ha/hour)	147 %	167 %
Fuel consumption (ha/liter)	124 %	148 %
Soil Incoherent (%)	110 %	125 %
Overall product weight (kg)	72 %	76 %
Transmission parts weight (kg)	84 %	75 %
Max. Efficiency (%)	108 %	115 %

Finally, when comparing with NC-S and A brand's, we got evaluation result of product as shown in Fig. 11.

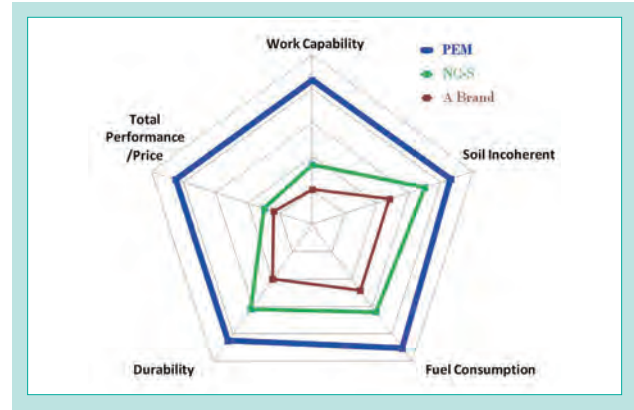

Fig. 11 Performance Comparison Result

5-2 Business impact

PEM480 was first launched in October 2015 in Myanmar and India, then it will be expanding to other emerging countries around the world from 2016. We forecast the sale volume as below Fig. 12 that the goal is for PEM480 to be world first ranked by market share.

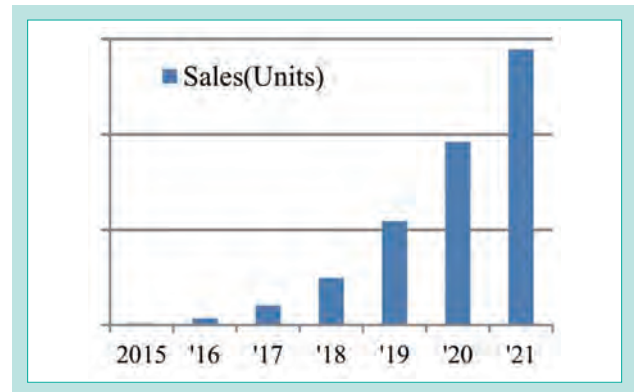

Fig. 12 Sale Volume Forecast

5-3 Next action

PEM480 currently has only 2 implements (rotary cultivator and disc plow) so the next challenge is to develop more implements to increase product versatility. Developing implements such as inter-

roll weeding for sugarcane field, ridge former implement for vegetable garden etc. will assist in the expansion of sales in various countries.

Reference

- 1) Pedro M.T. Marques, et. al., "Efficiency of a gearbox lubricated with wind turbine gear oils", Tribology International Journal, 71, pp. 7-16, 2014.
- 2) M.S. Hebbal, et. al., "Reduction of Root Fillet Stress by Alternative Root Fillet Profile", International Journal of Research in Engineering and Technology (IJRET), pp. 823-826, 2014 .
- 3) A. Kapelevich, et. al., "Tooth Fillet Profile Optimization for Gears with Symmetric and Asymmetric Teeth", GEAR TECHNOLOGY magazine, pp. 73-79, 2009.
- 4) V. Spitas, et. al, "Increasing the strength of standard involute gear teeth with novel circular root fillet design", American Journal of Applied Sciences 2 (6), pp. 1058-1064, 2005.

Development of “Non-Stop Baler” Technology

Kverneland Group Ravenna

Non-stop baling for reduced operator stress and fatigue, leading to improved operational efficiency; Increased output: Baling non-stop saves 15-18 seconds for every bale made. During a typical 300 bale day, this can give a time saving of over 1½ hours per day; Compact size: Despite its non-stop capacity, FastBale is smaller than other competitive baler wrappers, ensuring easy field access and stress free road transport; Simple bale transfer system and high speed vertical wrapping system

ensure high output and gentle bale release; Fully automatic operation, with animated real time display, keeps the operator relaxed and fully productive throughout long working days.

【Key Word】

Non-Stop Baling, High-Productivity, Compact, Automatic, Time-Saving

1. Introduction

Round baler output has always been limited by the above sequence - when the bale has reached its required size and density, the process of bale formation & forward motion have to be interrupted to bind and eject the bale.

For many decades round baler manufacturers have been searching for ‘round baler utopia’ – a technical solution to produce round bales without stopping. This is because round baler operators would like to avoid having to stop the baler for up to 20 seconds (or more, per bale) hundreds of times a day.

Until now no baler manufacturer has succeeded, however Kverneland’s dedication to technology development in line with the customers’ requirements lead us to the development of the innovative FastBale solution.

FastBale (Fig. 1) is in perfect alignment with customer

requirements – faster and more efficient bale production, high quality bales, reduced stress and fatigue for the operator and reduction in the consumption of fuel.

Ultimately, in line with Kubota’s slogan “For Earth, For Life” the FastBale project has focused on optimizing bale processing time, which reduces fuel consumption ensuring minimum waste of resources in terms of fuel and time. The Baler-Wrapper Combination market has until now been dominated by machines which need to stop to bind each bale. The current market-leader (Irish producer) has used this technology successfully until now.

Kverneland now wants to increase number of machines sold in this sector and become the future ‘reference’ for all professional baler-wrapper combination users, especially contractors.

FastBale features a unique multi-chamber baler design, which allows non-stop bale forming and binding, coupled with a unique wrapping unit. With this non-stop baling and wrapping, the constant 'stop-go' of round baling has been eliminated, round baling becomes a simpler and much more efficient process for the operator.

On average, traditional balers need to stop for 15 to 20 seconds for binding and bale discharge. In addition there is a tractor deceleration and acceleration phase for each bale. With FastBale we avoid this stop process, offering increased capacity of up to 30 %.

A contractor making 250 silage balers per day could save at least 1 hour per day ... better for the operator and better for his business.

In addition the multi-patented FastBale design offers

many other advantages, examples - simple operator use, baling capacity, bale density, compact design and multi-function.

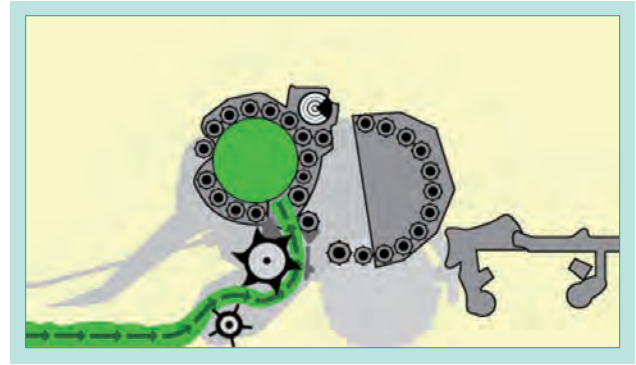

Fig. 2 Pre-chamber Filling

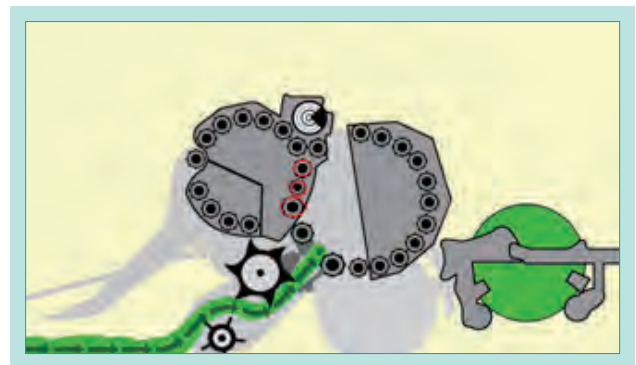

Fig. 3 Main Chamber Filling



Fig. 1 FastBale

2. R&D Concept and Target Value

2-1 R&D Concept

With Kverneland Group sourcing of balers relocated to Ravenna there was an urgent need for baler-wrappers in the product range, an important product area to maintain distribution network, high value product with a big opportunity for turnover growth and a possibility to re-enter this market and make progress against strong and well established competition; short term project to regain market presence by developing Flexiwrap product in cooperation with Goweil; decision to also start up a longer term development project to develop a market leading product. Strong feeling that we should strive to be innovative and should avoid launching a 'me too' product with little innovation. In Q3 2012 we had contact with an inventor, Seamus Varley who had come up with an idea for a

non-stop fixed chamber baler.

The Initial concept looked feasible and following discussions we suggested the idea would have further merit if it was also combined with a wrapper. We started the development with some functionality premises: Non-stop baling and wrapping cycle obtained by means of a perfect timing between all steps; Good crop flow from the ground to the pre-chamber positioned on top of the rotor (Fig. 2) ; Pre-bale transfer from pre-chamber to the main chamber with reduced crop loss (Fig. 3) ; Double compression of bale in the two chambers; Direct transfer of the bale from bale chamber to the wrapping system eliminating the requirement for any form of transfer system

2-2 Target Value

1. Increase productivity by the 30%;
2. Fuel consumption reduction;
3. Less stress for the driver and less risk to make

mistake in the baling cycle by having an automatic operational mode.

3. Technical challenge to be solved

From the beginning of this project, the major challenge to be solved is related to the electronic and the perfect timing in the bale-wrapping cycle; the timing is also related to the external influences:

- Tractor power;
- Oil flow;

Other technical challenges:

1. The machine needs to be as compact as possible, with a transport width below 28m and overall length minimized;
2. Driveline specification needs to be compatible with

working reliably in the wet silage conditions commonly found in Northern Europe;

3. A simple use control interface is a key element in a machine likely to be subjected to intensive operation;
4. Loading of net wrap and wrapping film consumables has to be quick and easy. Special focus as net unit is mounted high up on bale chamber;
5. FastBale must have a high level of reliability as it will predominantly be operated by customers making large numbers of bales, often in difficult conditions.

4. Developed Technology

4-1 Crop Flow

4.1.1 Technical Challenge

Crop Transport in all crop conditions from the pickup to the pre-chamber, transfer of the pre-bale from the

4.1.2 Solution of Challenge

Rotor dimension has been one of the main points of the project; the idea to have two chambers in order to have a continuous cycle and the need to build a compact machine, we developed the idea to position the pre-chamber on top of the feeding rotor. We experimented with various geometry and rotor sizes. As a result of our research, we choose an 800 mm diameter rotor geometrically positioned between the

pre-chamber to the main chamber and bale finishing without any cycle interruption.

two chambers to assure the feeding paths to both chamber starter rollers to be the same. This gives us assured crop transport in all crops from the pickup to the pre-chamber and main chamber also minimizing power consumption.

Illustrated in red, the length of the two feeding channels as the crop leaves contact with the rotors tines (Fig. 4, 5).

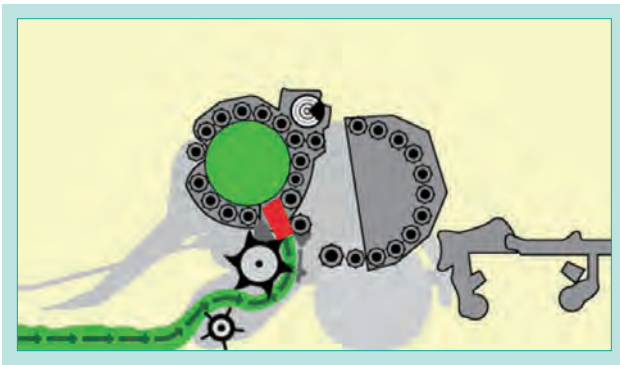

Fig. 4 Pre-chamber Feeding Channel

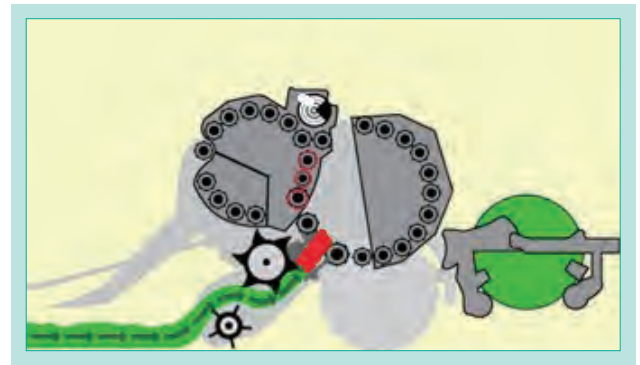

Fig. 5 Main Chamber Feeding Channel

4-2 Machine cycle times - Baling and wrapping

4.2.1 Technical Challenge

Software, Hydraulic and mechanical components have to communicate continuously in order to have

a perfect cycle and save effectively the 30% of the time compare a standard baler.

4.2.2 Solution of Challenge

The technology will not be sold based on no-stop baling only if the customer cannot justify the additional investment costs so during the concept phase we investigated the time savings (cost savings) for a potential customer to justify their investment. Our research showed that standard combination machines had baling + wrapping cycle

time of between 50 and 65 seconds depending on the manufacturer and model. During concept phase we performed some calculations to estimate our cycle time. We confirmed the achievable maximum cycle time to be 30 seconds during prototype field testing (Fig. 6).

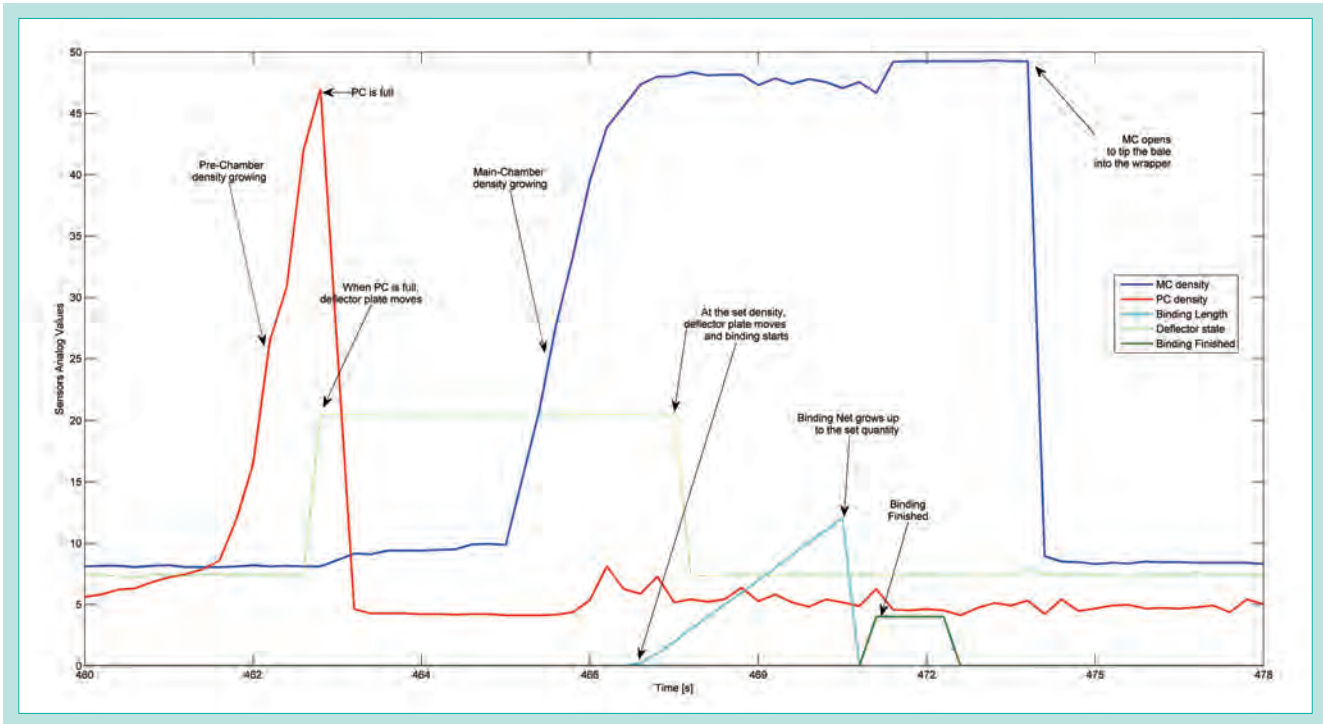

Fig. 6 Baling Cycle

4-3 Compact Baler

4.3.1 Technical Challenge

The machine needs to be as compact as possible due the fact that it has to go on the road and it needs to easy access in the field crossing a small gate which is quite common in the markets located in the northern Europe.

4.3.2 Solution of Challenge

In order to build a compact machine, we developed the idea to position the pre-chamber on top of the feeding rotor. The use of 'shared' rollers between the two chambers (Fig. 7)

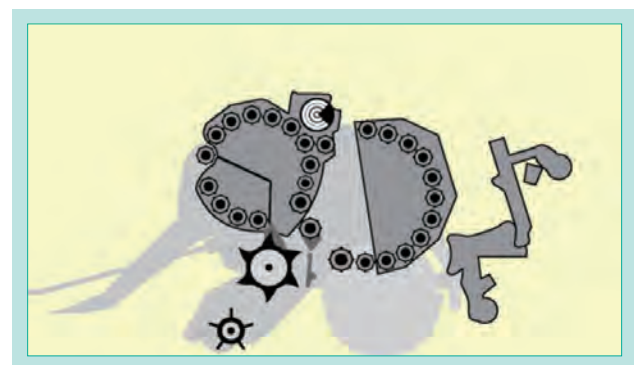

Fig. 7 Foldable Wrapper System for Road Transport

contributes to the compact overall dimensions of FastBale; In order to keep the shortest width we patented an internal transmission in the pickup (Fig. 8) keeping a maximum width of 2.2 m; the vertical wrapping system has been studied to keep Short overall length with small rear overhang. Vertical folding wrapper frame gives super short transport length (Fig. 9).

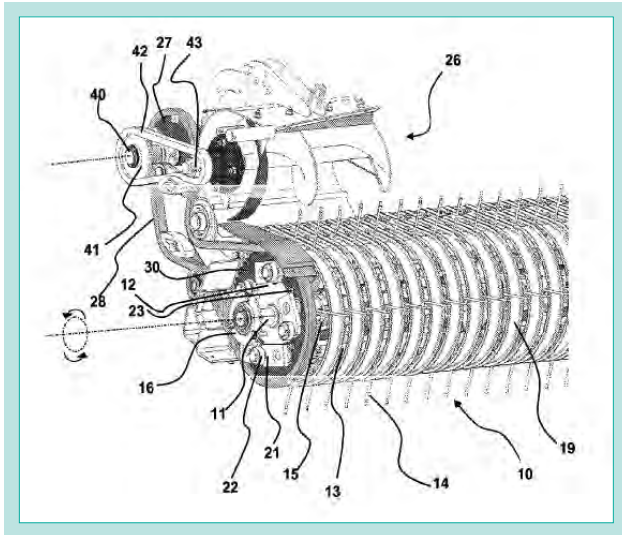

Fig. 8 Internal Transmission in the Pickup

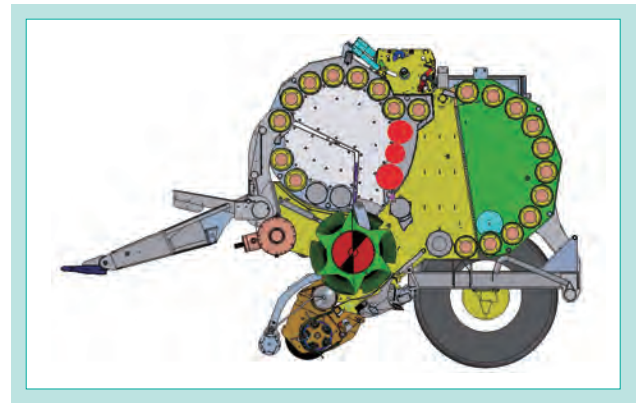

Fig. 9 Shared Rollers between Two Chambers

4-4 Bales Unloading in Vertical Position

4.4.1 Technical Challenge

In some cases the unloading of the bales in horizontal position doesn't suit the loader which has to load the bales into a truck; for some contractor is important

to unload the bales in vertical position in order to lift the bales with a Grab.

4.4.2 Solution of Challenge

The technical solution which is answering the market request has been developed and tested during the last two seasons; a round bar is mounted on the bottom of the wrapper and is moving during the folding cycle of the back frame of the wrapper at the

end of the wrapping cycle; the bar is pushing the bale on the side and it is rotating it in vertical position; the kit called "Bale Turner" (Fig. 10) is not increasing the length and the width of the machine.



Fig. 10 Bales Turner

5. Conclusion

FastBale is an innovative baler which can revolutionize the agricultural world:

- ▶Non-stop baling for reduced operator stress and fatigue;
- ▶less wear and tear on tractor transmission;
- ▶compact size, FastBale is smaller than other competitive baler wrappers, ensuring easy field access and stress free road transport;
- ▶simple bale transfer system and high speed vertical wrapping system ensure high output and gentle bale release;

- ▶fully automatic operation, with animated real time display, keeps the operator fully productive throughout long working days.

We expect to gain market share against strong competition; we plan to produce 70 machines in 2017 and 200 machines in full production from 2018.

Competitors' dealers are looking for alternatives and the FastBale is a product that should guarantee a reliable alternative with higher performances.

With FastBale we plan to reach in 2018 a 10% of market share in this segment.

Reference

For more info please look at the project micro site
www.fastbale.com

Development of Z700 Commercial Zero-Turn Mower

Turf Engineering Department of America

Kubota produces some products to satisfy zero-turn-mower estate customers. These products also appeal to zero-turn-mower commercial customers. However, some commercial customers are not completely satisfied. Machine performance, ergonomics, and cost are several areas where improvements could allow Kubota to satisfy the commercial customer more completely. By developing new technologies such as a manually-adjusted deck height system, a machine layout to reduce front axle

weight, and easy-to-operate parking brakes, the Z700 has successfully appealed to customers in the commercial market. As a result, Kubota has improved its ability to support the thriving life of humans while still caring for the environment of this beautiful earth.

【Key Word】

Zero Turn Mower, Ergonomics, Parking Brake, Mower Deck Height Adjustment

1. Introduction

1-1 Outline of the business

Since 2011, Kubota’s Turf Engineering Department of America has been developing and designing new models to increase and improve Kubota’s line up of turf care products. By designing and developing these new products in the United States of America, this

department has been able to significantly improve the working relationship with the manufacturing plant and sales division. This has allowed new models to be developed that are quicker to market with better customer-driven specifications.

Through intensive market surveys, it was determined that Kubota had a small market share of commercial zero turn rider (ZTR) mowers. Current Kubota offerings have many features that appealed to high-end and low-end consumer demographics. These features also appealed to some commercial customers. However, other commercial customers preferred a different level of performance and price. As a result, the Z700 Series was developed (Fig. 1).



Fig. 1 Z700 Series

1-2 Issues to be solved

In order to be competitive in the commercial ZTR market, the mower must excel in three general areas: functional performance, ergonomics, and cost. This was determined by studying the current competitors in the market and the current ZTR products offered by Kubota.

Commercial users require a ZTR that can make quick, small changes to the mower deck height as the machine is operated so they can avoid scalping the grass (cutting the grass too short) in uneven terrain. If the grass is cut too short, it can become diseased or die. The machine must also have a low front axle weight to allow the machine to traverse side-slopes easily. Machines that offer these capabilities have the

functional performance required for this market.

A successful commercial market ZTR must also have excellent ergonomics to allow the operator to use the machine for long periods of time without becoming tired. Many competitive machines in this market suffer from poor ergonomics.

The commercial ZTR market also requires the total cost of ownership (machine price, maintenance costs, etc.) to be low.

After careful study of the current competitors and Kubota products, it was found that many of the machines do not offer a complete mix of features to satisfy all of these criteria.

2. Outline of the development

2-1 Development concept

The development concept for this project was to design and produce a machine that would provide

superior functional performance, great ergonomics, and low total cost of ownership.

2-2 Target Value

In order to achieve the development concept, several challenging targets were set:

1. Improve the usability of the machine compared with current Kubota products such that the Z700 is specifically suited for commercial users.
2. To improve machine performance, reduce the weight

of the machine as much as possible such that it is less than its main competitor.

3. Improve the ergonomics and comfort of the machine to be class-leading.
4. Reduce the total cost of the machine compared to its main competitors.

3. Technical challenges and their target qualities / values

The following design targets were set to achieve the development concept:

1. Design a manual deck height adjustment system with separate transport lock lever. The ergonomics and function of this system should be improved over competitors and current Kubota products.
2. Develop a machine with a low front axle weight that can still traverse uphill terrain.

3. Develop an adjustable mower deck height pedal to increase the ergonomic capabilities of the machine.
4. Design a parking brake system that can be operated with one foot in order to improve the ergonomics of the machine.
5. Achieve the above items while keeping a low total machine cost.

4. Details of the development

4-1 Deck Height Adjustment System

Detailed analysis of competitors and current Kubota products in regards to their deck height adjustment system presented many opportunities for improvement.

Most current Kubota products offer a hydraulic deck lift system. This system requires low input forces from the operator, and is ideal for homeowners, estate operators, and some commercial users. However, other commercial customers need to be able to ‘float’ the mower deck over uneven terrain (i.e., change the mower deck height quickly by small increments while the machine is moving). This makes a hydraulic system unsatisfactory for this segment of the market.

Other Kubota products, and competitors as well, offer a manual deck lift system, but most of these systems automatically capture the mower deck in the highest position (which is called the “transport” position) when the deck reaches that height.

This means that if the operator manually adjusts the mower deck too high during operation, the mower deck can lock in “transport” automatically, which means the operator must stop mowing so they can move a lever to lower the mower deck again.

For the Z700 project, a new manual deck lift system was developed with a “Transport Lock Lever” to allow the deck to “float” without catching in “transport”. This allows the operator to disable the lever’s function so that they can control the deck height freely without the lever capturing the deck in “transport” (see top boxes of Fig. 2 vs bottom boxes of Fig. 2).

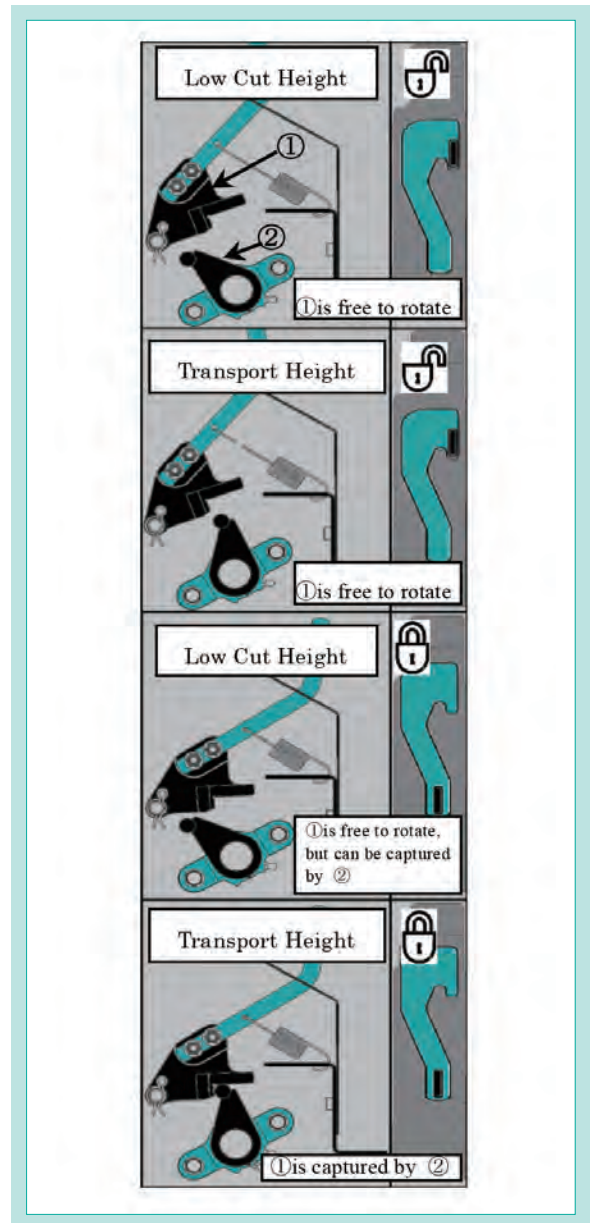

Fig. 2 Z700 Transport Lock Lever

4-2 Front Axle Weight

Current Kubota products and some competitors have a high front axle weight, which makes them difficult to operate on side-slopes because the front axles on a ZTR are free-moving and tend to go down the hill due to gravity. This high front axle weight is required to keep the machines stable on uphill slopes (stability on 25-degree uphill slope is required by safety regulations ; Fig. 3).

Many competitors and current Kubota products utilize fuel tanks that are located in the fender areas of the machine. This places the fuel high in the machine, raising the machine’s center of gravity (CG). This high CG means that weight must be added to the front axle of the machine to offset the high CG.

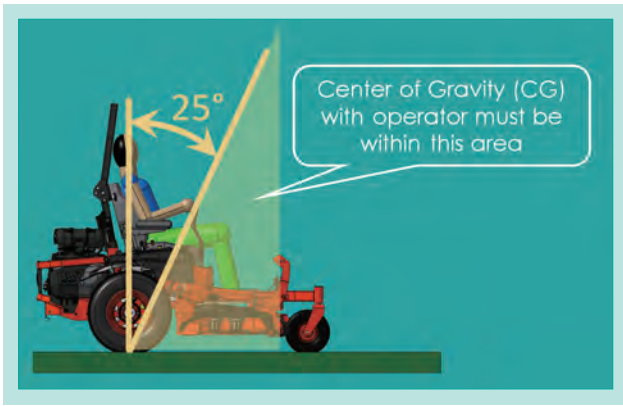

Fig. 3 ZTR Center of Gravity

Other competitors and some Kubota products place the fuel tank under the seat, which lowers the machine CG. Kubota products go one step further and move the air space for the fuel tank to the fender area so that the seat (and operator weight) can be moved as low as possible in the machine (Fig. 4), directly above the fuel tank holding liquid fuel.

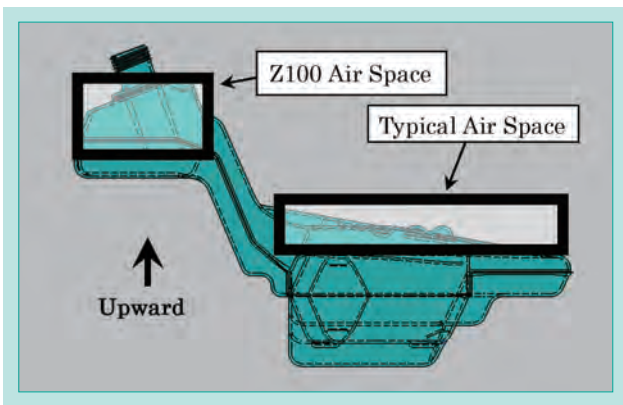

Fig. 4 Z100 Fuel System Air Space

The Z700 machine could not place the fuel tank air space in the fender area due to space constraints (mainly frame structure).

Therefore, a new layout was made that allowed

the airspace to move to the rear of the machine next to the engine (Fig. 5). This was accomplished by rotating the engine 90-degrees and placing the muffler on the left side of the engine. This created a large empty space to the right of the engine that could be occupied by the fuel tank (Fig. 6).

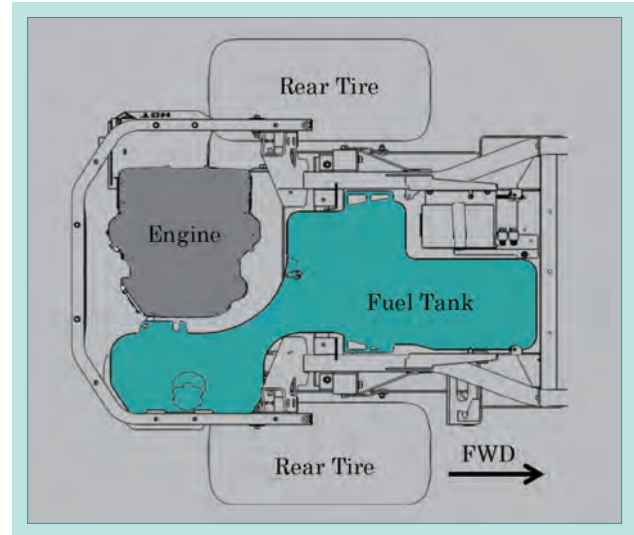

Fig. 5 Component Layout

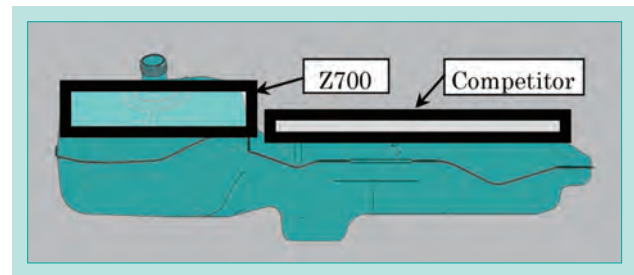

Fig. 6 Z700 Fuel System Air Space

This lowered the CG of the Z700 machine, and allowed the front axle weight to be reduced. As a result, the Z700 front axle weight is 4 kg less than one of its main competitors, and 15 kg less than the ZG200-series.

4-3 Mower Deck Height Pedal

Developing a machine that can comfortably fit many body types is very challenging. Competitors often use a system of adjustable control levers and seat slides in an attempt to maximize the percentage of people that they can accommodate. This type of system typically allows the machine to comfortably seat 82.5 % of people (based on their height)¹⁾.

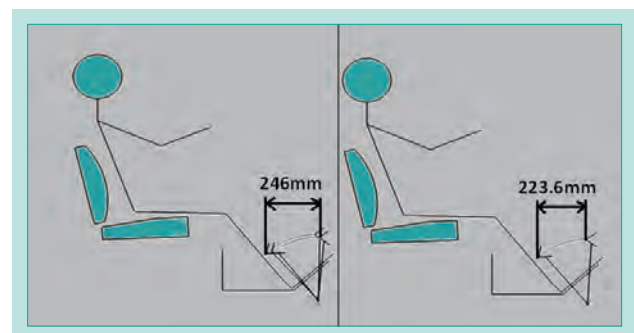

Fig. 7 Horizontal Stroke of Mower Lift Pedal

The Z700 machine uses adjustable control lever and seat slides also, but also incorporates an adjustable mower deck height pedal (Fig. 7) to accommodate 90.1 % of people based on height (Fig. 8).

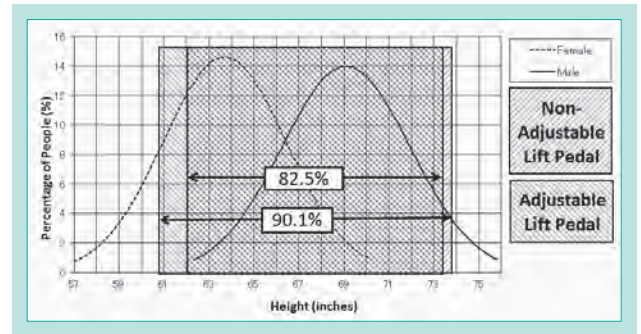

Fig. 8 Percentage of People vs Height

4-4 Parking Brake System

Competitor machines often use a parking brake system that is applied using the operator's hand. This lever (Fig. 9) is also usually located in a place that makes it very difficult to access unless the control levers are in the neutral position.

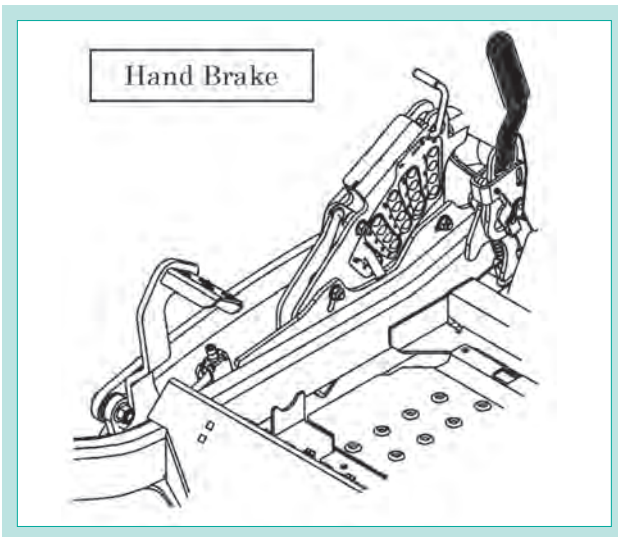

Fig. 9 Competitor Hand Parking Brake

This is an inefficient system as it requires the operator to use his hands to perform four actions in order to stop and park the machine:

1. Move control levers to neutral position.
2. Place control levers in neutral lock.
3. Lean forward to grab parking lever.
4. Pull up and backward to engage parking brake.

The Z700 machine uses a one-foot-operated parking brake system that allows the operator to stop the machine by only performing three actions:

1. Move control levers to neutral.
2. Place control levers in neutral lock.
3. Step on parking brake pedals to engage parking brake.

This system is not so dissimilar from current Kubota parking brake systems. However, those systems require two feet to operate because the lock

pedal and main brake pedal must move in different directions to achieve engagement. The Z700 brake system aligns the travel direction of the lock pedal with the travel direction of the main brake pedal, allowing the operator to activate both pedals with only one foot (Fig. 10).

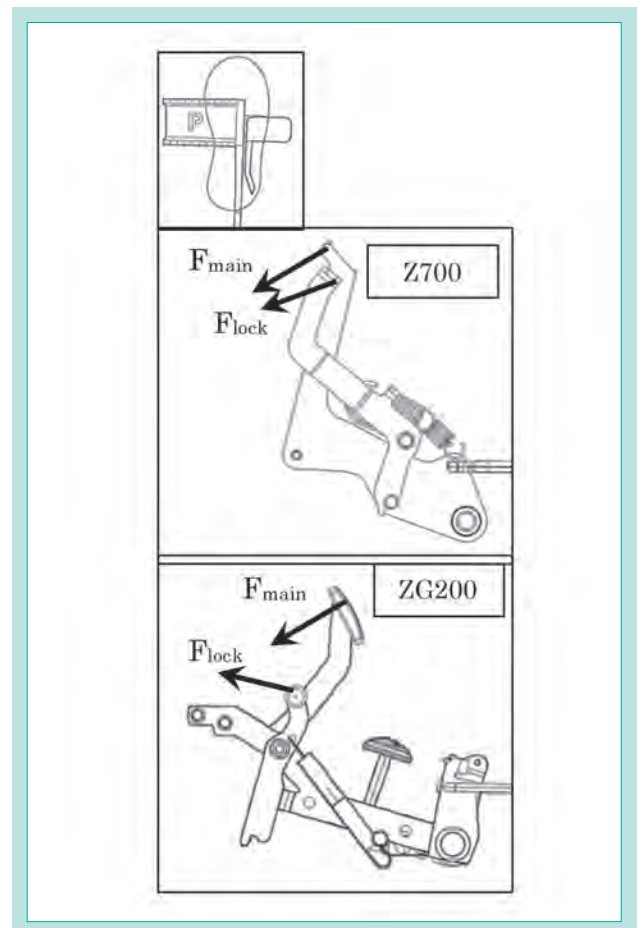

Fig. 10 Z700 and ZG200 Parking Brake Operation

4-5 Machine Cost

Competitor machines in the commercial ZTR market segment have been increasing in price year after year. This presents a great opportunity for Kubota to enter this market if the machine can offer improved

features without impacting the purchase price.

The Z700 project was able to develop and design the above improvements and still maintain a cost that is more than 10 % lower than its main competitor.

5. Conclusion

5-1 Evaluation of the achievement

The Z700 project was able to develop a machine with a complete mix of features to satisfy commercial customers, including superior ergonomics and great functional performance.

Impressive ergonomics were achieved due to the optimized locations and functions of the parking brake system and transport lock system. An adjustable mower deck height pedal also contributed to the superior ergonomics of the machine.

Outstanding functional performance was achieved by improving the functionality of the transport lock system. The locations of the fuel tank, engine, and muffler also contributed to improve the operating performance of the machine.

All of these features were designed without severely impacting the purchase price of the machine. In fact, the Z700 machine has a 10 % lower purchase price than its main competitor.

5-2 Contribution to the business

The Z700 project, due to its great design, achieved its first-year retail sales target. This accounted for Kubota's North American unit sales increasing by 8.5 % (Fig. 11).

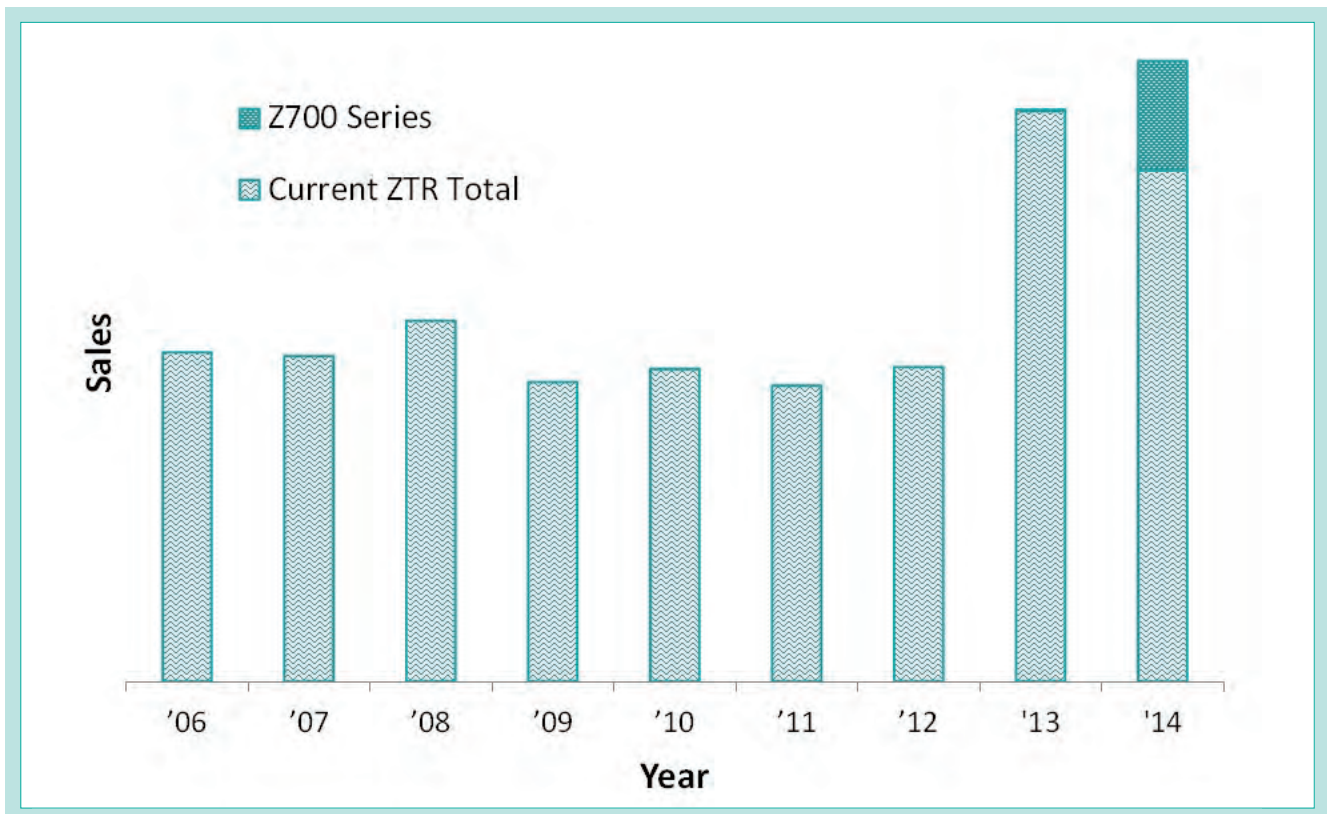

Fig. 11 Kubota ZTR Sales

Reference

- 1) Robert Walden (2013) Development of ZG100 "Homeowner Zero-Turn Mower".

Development of Riding Type Rice Transplanter SPV for Overseas

Transplanter Engineering Dept.

Rapid economic development in emerging countries is leading to escalating personnel costs (the costs for rice cultivation, too), and making it difficult to secure labor. Consequently, mechanization of rice cultivation in such countries (China and so on) is taking place. Rice transplanters in emerging countries tend to be used in the following way: the land owner entrusts rice planting to the owner of the rice transplanter, and the land owner pays a fee to the rice transplanter owner in proportion to the transplanted area. The larger the area planted, the more rewards the owner of the rice transplanter will receive. Based on this background, an ability to plant larger area, in other words a "profitable machine," is

required. To meet this demand, Kubota has developed new rice transplanters based on the concept of "global 6- and 8-row riding type rice transplanters which are able to produce a profit for user and have a basic performance." In this paper, we explain the technical development we conducted to meet three requirements—high efficiency, high durability and ease of maintenance—which are directly related to profitability.

【Key Word】

Emerging Countries, Riding Type Rice Transplanter, High Efficiency, High Durability, Ease of Maintenance

1. Introduction

There is rapid economic development in the emerging countries of the world and it is leading to a rise in labor cost, with industrialization in urban regions in the background. It has also caused the population to concentrate in urban areas¹⁾ and led to a shortage of people in agricultural areas²⁾ at the same time. Due to these reasons, agriculture is changing from the conventional form where it was done manually to one where it is done by machines³⁾ (Fig. 1).

There are many trends in these emerging countries that are different from those of the Japanese market. While the mainstream in Japan is for landowners to purchase a rice transplanter to transplant on their own land, "rented transplanting," in which landowners entrust an owner of a rice transplanter to do the transplanting on their land and pay in proportion to the area planted, is the most popular form in emerging countries. Due to this, there are demands for profitable machines that are capable of transplanting

as large an area as possible in a day.

Meanwhile, there are also many characteristics different from those of Japan in the working environments for rice transplanting in emerging countries, and several issues have to be solved before a profitable machine can be produced. We worked on these issues and developed the SPV Series, riding-type rice transplanters which are profitable and suited to the markets of emerging countries.

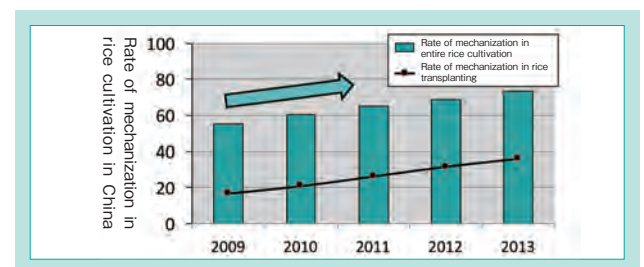

Fig. 1 Rate of Mechanization of Rice Cultivation³⁾

2. Development concept and objective values

To develop a machine suited to the needs of emerging countries, we set our concept as "global 6- and 8-row riding-type rice transplanters which can produce a profit for the user and have a basic performance." To address this, we focused on the following three items:

(1) High efficiency

The greatest advantage for the user is how large an area the machine is capable of transplanting in a day. We set the goal of being able to transplant while maintaining high efficiency under various different field environments found in emerging countries.

(2) High durability

The transplanting work must be halted if a failure occurs in the rice transplanter, and this results in a

(3) Ease of maintenance

The rice cultivation areas are much larger in emerging countries than in Japan, and there is a limit to the area a service person can cover to provide maintenance for all rice planters. We set the goal of having a structure where the machine maintenance is easy enough for the users to implement it by themselves even in such regions.

3. Technical issues to be solved

3-1 Issues to be solved for high efficiency

(1) Reduction in oil temperature

There are gigantic rice paddies with the long sides exceeding 1 km in emerging countries (Fig. 2 top). If the farmers run out of seedlings loaded on the rice transplanter during the transplanting work, they have to go back to the ridge, which is at edge of the paddy, to reload the seedlings. This results in additional time being required for returning to the ridge and reloading the seedlings. This time becomes longer the larger the paddy is. To minimize this, users try to load a large amount of seedlings onto the transplanter (Fig. 2 bottom). In addition, to transplant in larger areas, two or three other people often ride the rice transplanter along with the operator to supply the seedlings in these emerging countries. Due to the loading of a large amount of seedlings and three to four people riding on the transplanter, it may have to bear more than its own vehicle weight (600 to 800 kg), ending up with an extremely large load. Meanwhile, rice transplanters adopt a hydrostatic continuously variable transmission (HST) as the transmission mechanism, and it works by hydraulic forces. The temperature of the hydraulic oil increases when a large load is applied to the HST. This causes the viscosity of the hydraulic oil to decrease and some of the oil needed for power transmission leaks out, resulting in losses and a deterioration in the power transmission efficiency of the HST. Especially if the working environment has an atmospheric temperature exceeding 35 degrees Celsius in addition to severe conditions of large paddies where large loads are applied for a long period, deterioration in power transmission efficiency of the HST occurs in a more prominent fashion and results in less efficient transplanting work.

(2) Escape from deep paddies

The depth of mud in a paddy is not always even in emerging countries, and the paddies often have spots with deep bottoms (deep paddies) here and there. The rice transplanter may become stuck in these

deep spots and it may be impossible for it to escape on its own. In such cases, it needs to be pulled out with a tractor and so forth using a towing wire (Fig. 3). This often causes long pauses in transplanting work and results in lower work efficiency.



Fig. 2 Large-scale Paddy and Rice Transplanting in Emerging Countries



Fig. 3 Rice Transplanter Escaping from Deep Paddy

3-2 Issues to be solved for high durability

Triple cropping is the mainstream method of agriculture especially in tropical areas such as Thailand and India, indicating that the farmers there are transplanting rice throughout the year.

Thus, the annual period of machine use is 10 times or more the general period of use in Japan. Such long periods of use naturally lead to more failures, and rice transplanters with high durability are demanded.

3-3 Issues to be solved for ease of maintenance

It is possible to minimize the pauses in transplanting work by preventing any failure caused by insufficient maintenance and making it easy to replace consumable parts. Especially

in remote and wide rice cultivation areas where services are hard to obtain, it is important that the users can implement maintenance by themselves.

4. Developed technology

4-1 Technical development for high efficiency

4.1.1 Oil-temperature-reduction technology for HST hydraulic oil

The HST hydraulic oil of conventional machines circulates between the HST and transmission case. In this structure, the cooling surface area is small, and the oil temperature tends to increase easily in transplanting work in large paddies under high temperatures and large loads. To suppress the increase in oil temperature, we examined the adoption of a special oil tank or oil cooler to increase the cooling surface area. However, these led to problems such as it being nearly impossible to ensure a sufficient installation space, cost increase and weight increase. For the developed machine, we eventually increased the cooling surface area by incorporating the rear axle case, which is an existing part between the HST and transmission case, into the hydraulic circuit (Fig. 4). Thanks to this, heat is released from the hydraulic oil which is heated at the HST during transplanting work under high loads as it circulates via the rear axle case and has cooled to a low temperature by the time it returns to the HST again (Fig. 5). This prevented the power transmission efficiency of the HST from deteriorating, and enabled the transplanter to keep operating without a decrease in work efficiency even under high temperatures and high loads.

4.1.2 Addition of auxiliary transmission lever for escaping from deep paddies

We examined adding a function to allow the transplanter to escape by itself without needing to be pulled with a tractor and so forth when it is stuck in a deep paddy. The developed machine was given a pinion gear at the HST output shaft which can be used to switch between high and low settings with a lever (Fig. 6). This made it possible for the transplanter to escape a deep paddy by itself by switching to the low setting to reduce the vehicle speed and increase the axle torque, while carrying out normal transplanting work at the high lever position. Now the transplanter can escape on its own even when it is stuck in a deep paddy by only switching the lever, and we were able to reduce the loss in transplanting work.

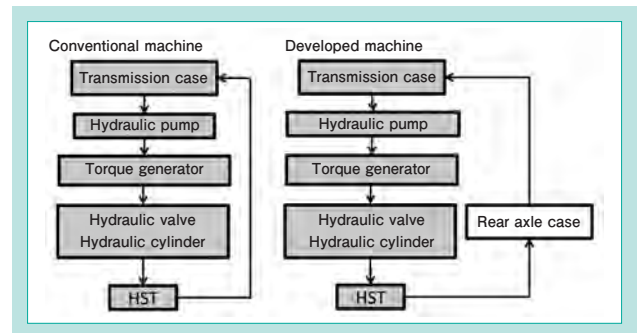

Fig. 4 Change of HST Hydraulic Oil Circulation

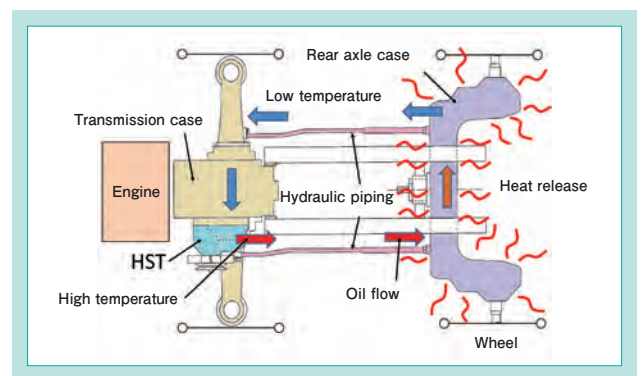

Fig. 5 Reduction of Oil Temperature by Promoting Heat Dissipation from Rear Axle Case

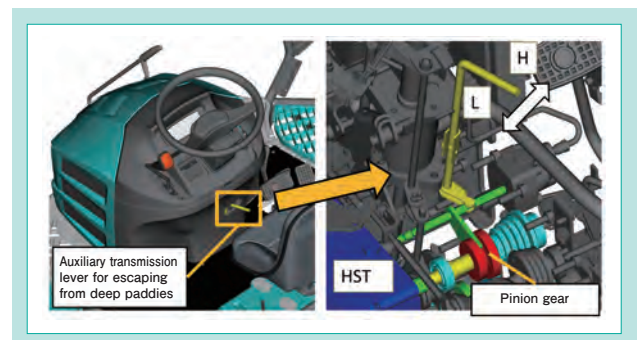

Fig. 6 Sub-shift Lever for the Purpose of Escaping from Deep Paddy

4-2 Technical development for high durability

The unit in the back of the rice transplanter that plants the seedlings is called the transplanting unit. When operating a rice transplanter, the planting claw nips the seedlings and plants them into the paddy while the seedlings set in the seedling table move reciprocally to the right and left in what is called cross-feeding (Fig. 7). Since the transplanting unit has a complex structure and continues to operate while being in constant contact with the surface of muddy water, there were problems in terms of durability under severe operating conditions like those in emerging countries. This section introduces our measures to improve the durability of this transplanting unit.

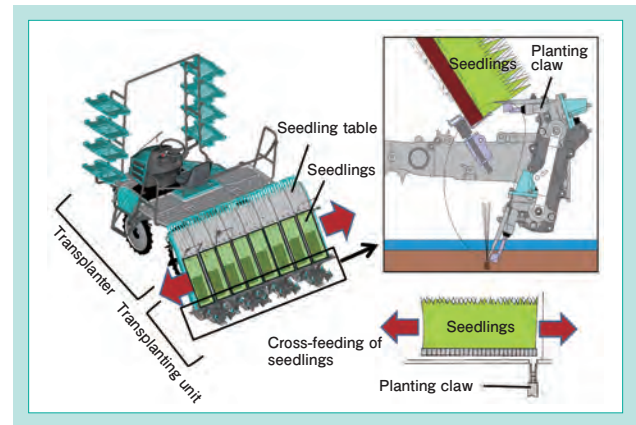

Fig. 7 Overview of Transplanting Unit

4.2.1 Roller-type cross-feeding support structure for seedling table

Cross-feeding seedlings is the operation to set the seedlings on the seedling table and have the planting claw nip them as they are moved horizontally during transplanting work. The support structure for this cross-feeding in the conventional machines had adopted a sliding part (made of resin). In this case, the sliding resistance increased as mud adhered to the sliding surface when transplanting work was done in a paddy, resulting in wear of the sliding support part and the need to frequently replace the slider. The load on the cross-feeding drive section

also increased as the sliding resistance increased, making it problematic in terms of durability.

We eliminated the slider-type cross-feeding support structure and came up with a roller-type support structure in the developed machine (Fig. 8). Unlike the slider type, there is no sliding but rolling, eliminating the generation of wear and achieving cross-feeding without the need for maintenance for a long period. Furthermore, it reduced the cross-feeding load and lightened the load on the cross-feeding drive section, resulting in improved durability.

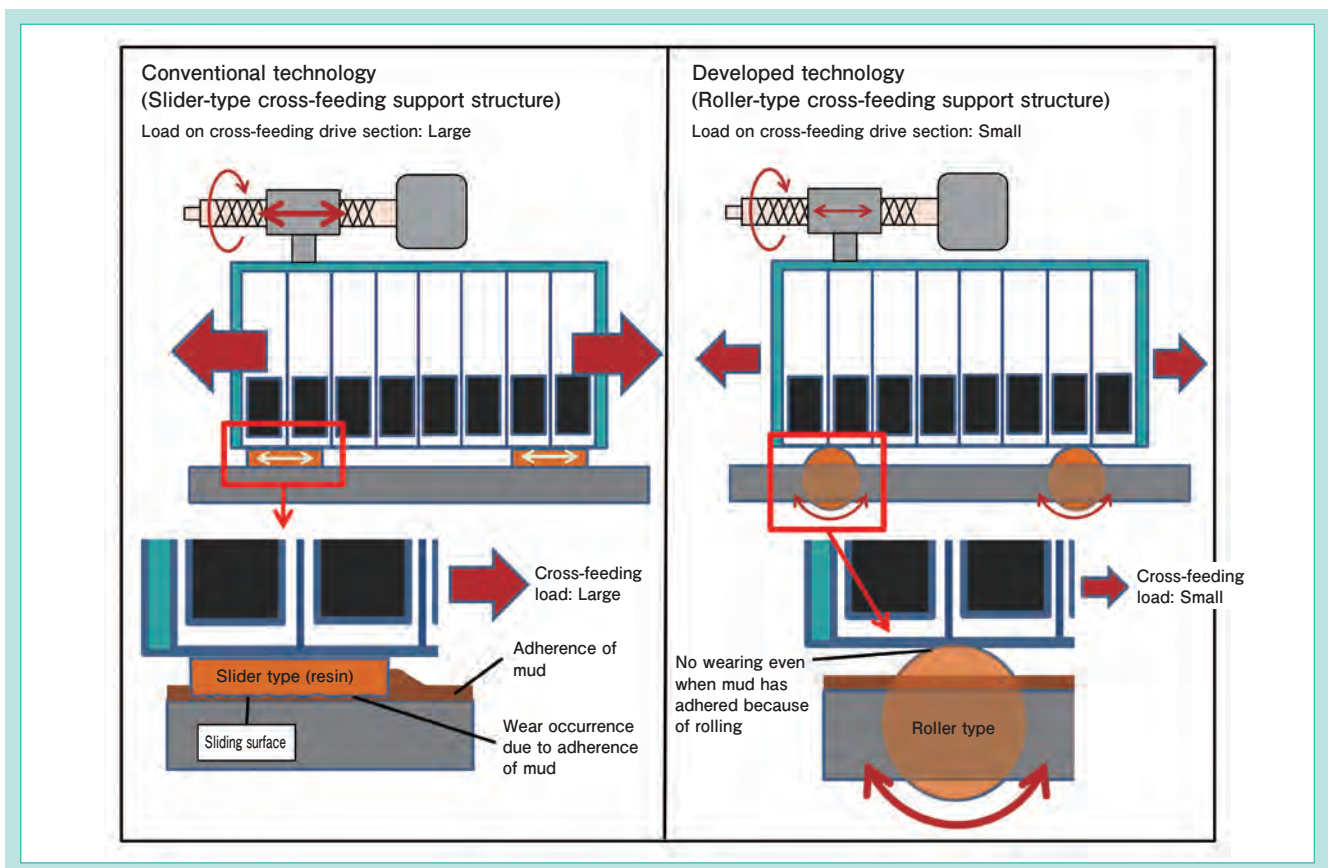

Fig. 8 Roller Type Seeding Table with Cross-feeding Supporting Structure

4.2.2 Improvement in durability of planting claw

A planting claw is an important part which nips the seedlings and plants them in the paddy ground. However, it is used in an especially severe environment, as it operates at a high speed in mud, and it tended to fail as mud entered inside the part, therefore resulting in demands for greater durability. However, when we investigated the failed parts we found the insides of planting claws were covered in mud and it was impossible to tell where the mud had entered from.

To elucidate this, we predicted that signs of failure should be observable if we studied the planting claws which were being used and which had not failed, and collected undamaged planting claws from users of various regions in China to disassemble and investigate them. Clayey soil is typically found in northern regions of China including Heilongjiang Province and Liaoning Province, and the mud does not come off easily once it adheres to the planting claw. On the other hand, double or triple cropping is most popular in eastern and southern parts of China such as Jiangsu Province, Zhejiang Province and Hainan Island, and the farmers there start planting again immediately after harvesting. Therefore, a lot of straw remains in the field, indicating that the oil seal to prevent mud from entering the machine may become worn as straw is caught by the planting claw and this could result in an early failure. We

investigated the planting claws used in these regions and analyzed the trends. The results were as follows:

- It was confirmed that mud entered from the cam shaft side of the planting claw and that was the starting point of the damage (Fig. 9 left center).
- While the presence of straw had little effect on the entry of mud, the effect of soil type on mud entry was confirmed. Mud was observed to often enter the part from the cam shaft in areas with clayey soil.

We observed how mud entered from the small gap in a nut from the cam shaft side and accumulated inside the side lip of the oil seal under severe operating conditions in mud (Fig. 9 right). We found that clayey soil was not cleared from the inside once it accumulated, and that it shortened the life of the oil seal and caused more mud to seep into the planting claw.

To stop mud from getting in the cam shaft side, we took the following technical measures (Fig. 10):

- [1] Prevented mud from entering the gap in the nut by changing the cover shape, and
- [2] Reduced fluctuations in the cam shaft by changing its structure to one that is supported at both ends

These changes dramatically reduced the amount of mud entering from the cam shaft side (Fig. 11), and we were able to develop a planting claw capable of enduring the severe operating conditions of emerging countries.

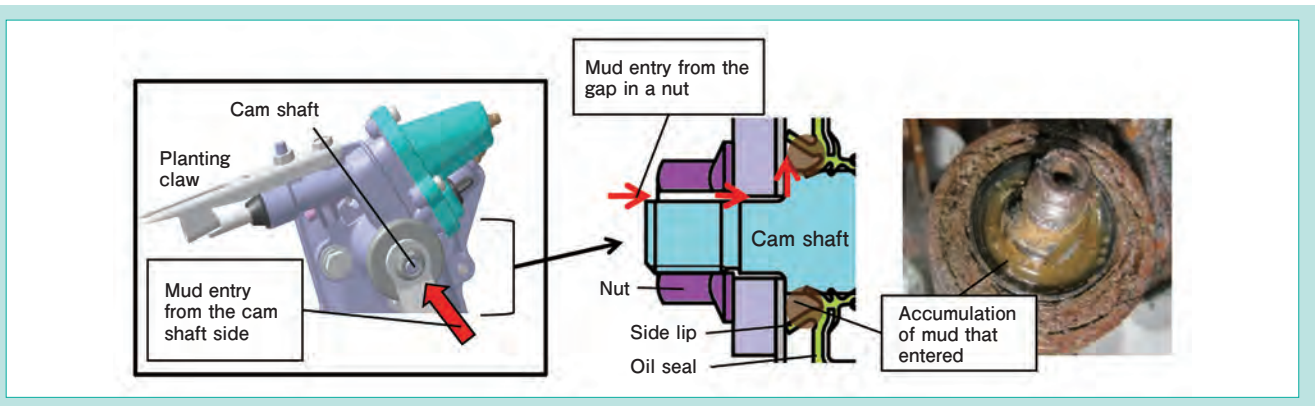

Fig. 9 Problem of Conventional Planting Claw

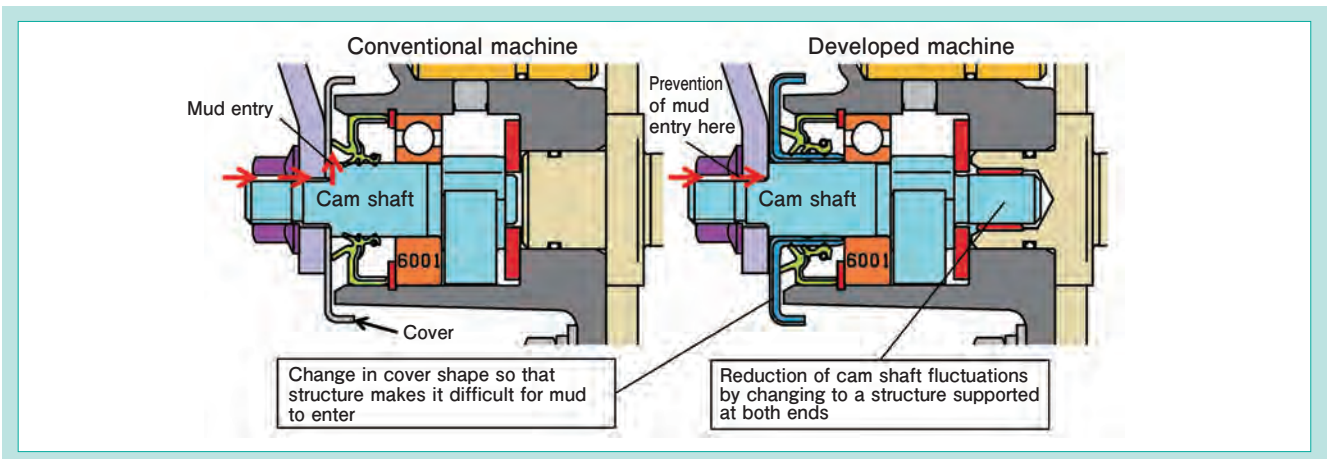

Fig. 10 Planting Claw that Keeps out Mud

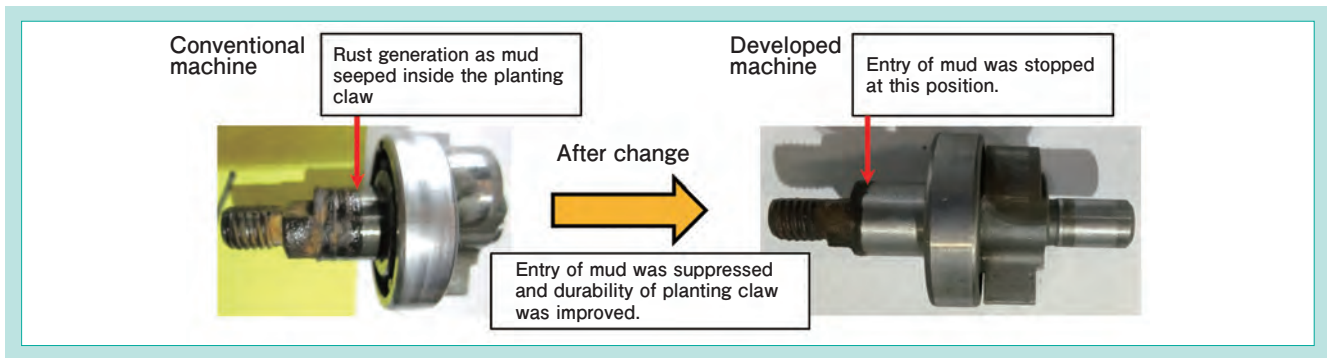

Fig. 11 Effect of Planting Claw Improvement

4-3 Technical development to improve the ease of maintenance

The relay, fuse, battery, hydraulic valve and fuel filter often require maintenance in rice transplanters, they are located in different parts of conventional machines, and some of them cannot be maintained unless the exterior parts are removed. Compared with this, we concentrated these parts under the seat and changed their layout in our developed machine so that the user can access them easily (Fig. 12).

We also made improvements such as changing the structure to enable the oil seal to be replaced without disassembling the case, adding a grease nipple to facilitate daily maintenance, and shipping the product by including standard parts and consumable parts in accessory parts. In these ways, we improved the ease of maintenance.

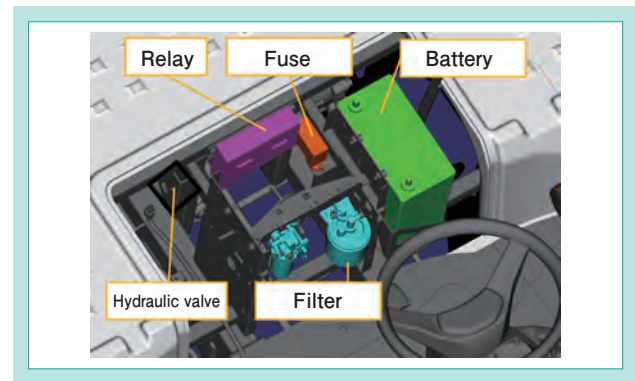

Fig. 12 Central Maintenance Structure Beneath Seat

5. Conclusion

We implemented product development with the focus on high efficiency, high durability and ease of maintenance, with the concept of global 6- and 8-row riding-type rice transplanters which are able to produce a profit for the user and have a basic performance. These attributes satisfy the needs in emerging countries (Fig. 13).

Our developed product was released in China, and has received high evaluation from the users in our seasonal operation survey. In the future, we plan to roll out the developed machine in various different countries.



Fig. 13 Developed SPV Series

Literature

- 1) Chinese Economic Network: Office for National Statistics: The rate of urbanization in China reached 54.77% in 2014, (2015)
http://www.ce.cn/xwzx/gnsz/gdxw/201501/20/t20150120_4386891.shtml
- 2) Chinese Social Science Network: Population characteristics and problems of urbanization in China, (2014)
http://www.cssn.cn/shx/201404/t20140421_1077330.shtml
- 3) Chinese Industry Information: Current situation of agricultural machinery industry and analysis of development tendency in our country for 2015 (illustration), (2015)
<http://www.chyxx.com/industry/201507/329067.html>

IoT Solution System of Water Environment Infrastructure Facilities: KSIS (Kubota Smart Infrastructure System)

Instrumentation and Control Technology Center/
Water & Environment R&D, Water & Environment R&D Dept. II / Pump Systems Dept.

Nowadays, with regard to operation and maintenance of water environment infrastructure facilities, energy saving, cost saving, improvement in work efficiency, and longevity of facilities are required, and IoT (Internet of Things) technology is necessary for Kubota to meet the needs of its customers. Kubota has provided services such as the remote pump monitoring system¹⁾ and the remote liquid membrane monitoring system through Internet for over 10 years.

The demand for IoT system is increasing from a number of our customers of our business unit divisions of Water & Environment and Electronics. We launched a cross-sectional project and created KSIS, a common platform for the remote monitoring and diagnosis. KSIS connects the products of Kubota with IoT to provide a variety of solutions to many customers.

In this paper, we describe the development of products such as data transmission equipment, the cloud server and the establishment of a network for them through the

R&D on technologies for the wireless communication and the security for the cloud server. We also report on our efforts to expand them to the global market.

【Key Word】

Telecommunication, Wireless Communication, Remote Monitoring, Cloud Service, IoT, Security



1. Introduction

In concurrence with the changes in social situations today, the following problems have become apparent in local municipalities, which are our major domestic customers in the water and environment business:

- Aging and updating of facilities
- Decline in finance and shortage of employees
- Large-scale disasters and crisis management

Many of the municipalities, especially small- and medium-sized ones, often have hard time solving the above issues as they are busy dealing with daily work because of the shortage in the number of employees.

Meanwhile, when we export a water/environment plant to an overseas destination, we must establish the operation and maintenance service system after delivery. However, it may be difficult to do so because of insufficient skills of the local engineers.

We are therefore trying to establish a common platform which can be used for various products and services by fusing the telecommunication and artificial intelligence (AI) technologies with the application technologies Kubota has accumulated so far including our know-how on machinery. This will mean that various issues of the customers inside and outside Japan can be solved and our services can be improved through visualization and diagnosis using the Internet of Things (IoT).

According to the "Fiscal 2016 White Paper Information and Communications"²⁾ by the Ministry of Internal Affairs and Communications, the estimated number of IoT devices connected to the global Internet is 17.5 billion in 2016 as shown in Fig. 1. While the ratios of consumer products such as household appliances, audiovisual (AV) devices, sports and fitness products as well as telecommunication devices such as smartphones are high, Fig. 2 shows that utilization of the IoT for industrial applications is already large and has a high growth rate. For example, in production facilities at plants, programmable logic controllers (PLCs) and many sensors that are linked to them are connected to the network as IoT devices and they collect information for monitoring and control.

In June 2016, Kubota concluded a "partnership agreement for creation of ICT innovations in the agriculture, water and environment infrastructure fields" with the NTT Group. We plan to create comfortable living environments domestically and internationally through further advances in water and environment infrastructure solutions as well as in machinery in this agreement.

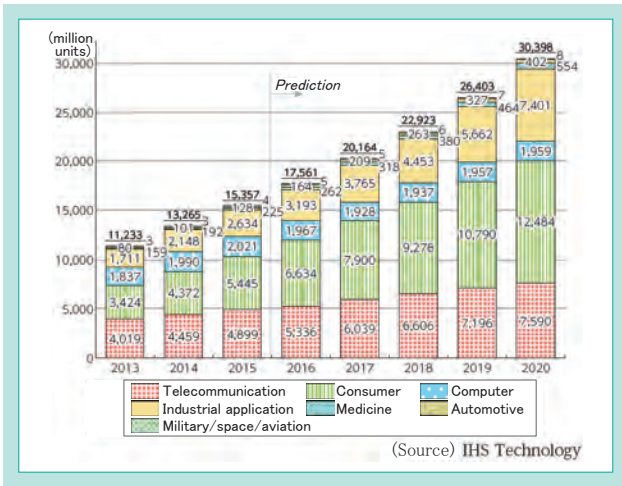

Fig. 1 Trends of IoT Devices Connected to Internet

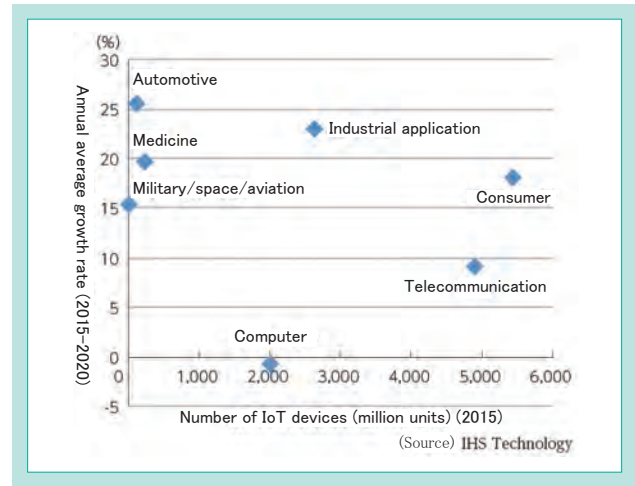

Fig. 2 Number and Growth Potential of IoT Devices in Different Fields and Industries

2. Development concept and goals

2-1 Development concept

We set our development concepts for the common platform, which can be used in various fields including waterworks and sewerage, rivers, and agricultural water, as follows:

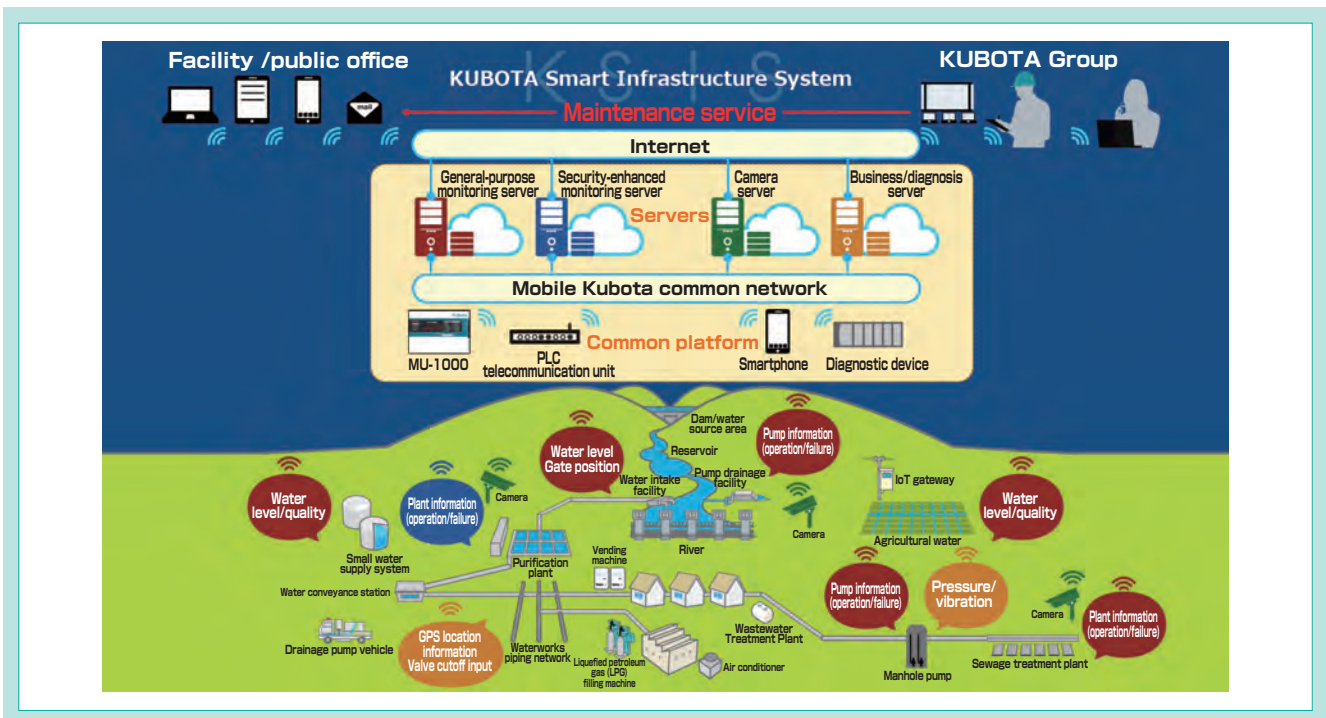

Fig. 3 Schematic Diagram of KSIS

- Provision of systems and services useful for operation and maintenance even after the delivery of single-unit machines or machinery and plants
- Provision of remote monitoring and diagnosis incorporating the proprietary know-how of KUBOTA as a machinery manufacturer
- Non-stop system with ensured security and resistance against disasters
- Improvement in synergic effects among domestic and international entities crossing boundaries of divisions and groups, and promotion of overseas business expansion

2-2 Overview of KSIS

KSIS, which was developed as a common platform in order to address the above concepts, is comprised of the following elements:

2.2.1 Telecommunication terminal on the facility side

For plants, we provide Kubota MU-1000¹⁾ and PLC telecommunication units as telecommunication devices to collect information on the facility. MU-1000 is used for devices as well as small- to medium-sized plants, while a PLC telecommunication unit is used for large-scale plants with large numbers of monitoring points. Table 1 summarizes the specifications of these products.

Table 1 Specification of Communication Terminals

	MU-1000	PLC telecommunication unit
Digital input [Di]	20 nos(* 220 nos)	About 2,000 nos
Analog input [Ai]	4 nos (* 84 nos)	About 200 nos
Digital output [Do]	4 nos (* 44 nos)	About 100 nos
External dimensions	W260 × H180 × D90	—
Power supply	AC100 V, AC200 V, AC220 V	AC adapter
Power consumption	15 W	—
Outage compensation period	3 hours	None, external UPS
External memory	CF card	—
Optional parts	* Expansion unit	—
Monitoring application examples	From large-scale facilities such as purification plants and treatment plants to small-scale facilities such as drainage basins and manhole pumps	Large-scale facilities

2.2.2 Server configuration

As shown in Fig. 3, the platform is comprised of four types of servers. They are installed in a data center with excellent earthquake resistance which is equipped with a backup power supply to ensure reliability.

(1) General-purpose monitoring server

A server whose operation began in 2003 and which has been mainly used in remote monitoring of sewerage and so forth. By installing the servers in two different sites, resistance to disasters including large earthquakes is increased.

(2) Security-enhanced monitoring server

Remote monitoring server to update the information automatically in real time every minute. It has enhanced security, including the use of one-time passwords for login.

(3) Camera server

A camera server in which the video from the camera is updated every minute. Video monitoring is done by utilizing a FOMA[®] line (stands for Freedom of Mobile Multimedia Access; it is the brand name of 3G telecommunications services offered by the Japanese telecommunications service provider NTT docomo) which requires no installation of optical fibers and so forth. Equipped with multi-screen display and recording functions.

(4) Business/diagnosis server

Server equipped with facility diagnosis and so forth using industrial systems for construction supervision and AI.

The charges for using these servers are set at a price which encourages the customers to use them. For example, the charge for using the general-purpose monitoring server starts from 900 yen per month, including the communication expenses.

3. Technical issues to be solved

To expand adaptable applications and achieve overseas expansion for the diverse water, environment and electric products and services based on the existing MU-1000, we had to solve the issues in development as listed below:

(1) Global measures for telecommunication terminals

We have expanded cloud monitoring in the water and environment fields mainly in domestic sewerage. However, telecommunication terminals that can be used overseas are required in concurrence with the expansion of cloud monitoring into various applications in waterworks, agricultural water, rivers and the environment and export of machinery and plants.

(2) Maintenance of compatibility with domestic telecommunication

For global support, there are various different telecommunication carriers and their types vary depending on each country. The system must be constructed by selecting the overseas telecommunication lines while maintaining commonality with the current domestic telecommunication network.

(3) Construction of global network

While we have provided cloud services on a system utilizing FOMA[®] for domestic facilities, construction of a network which can be used overseas is necessary.

(4) Ensuring strong security

To provide the service to various domestic and international users, it is necessary to ensure strong security.

4. Developed technology

4-1 Establishment of global telecommunication technology

To implement wireless telecommunication overseas, it is necessary in many countries to obtain certification for the wireless device to be used. Overseas support will be provided by connecting a certified wireless device to MU-1000 (Fig. 4).

While an overseas carrier is used for the telecommunication infrastructure, SIM supported by the NTT Group, which has partnerships with other overseas carriers, will be adopted to ensure secure end-to-end telecommunication with domestic servers.

Furthermore, since 2G/3G instead of 4G is the global mainstream as shown in Fig. 5 and many of the mountainous areas in Japan are also supported only by 3G, 3G telecommunication which has no

problem in data communication speed is adopted.



Fig. 4 MU-1000 and Wireless Device Compatible with Overseas Use

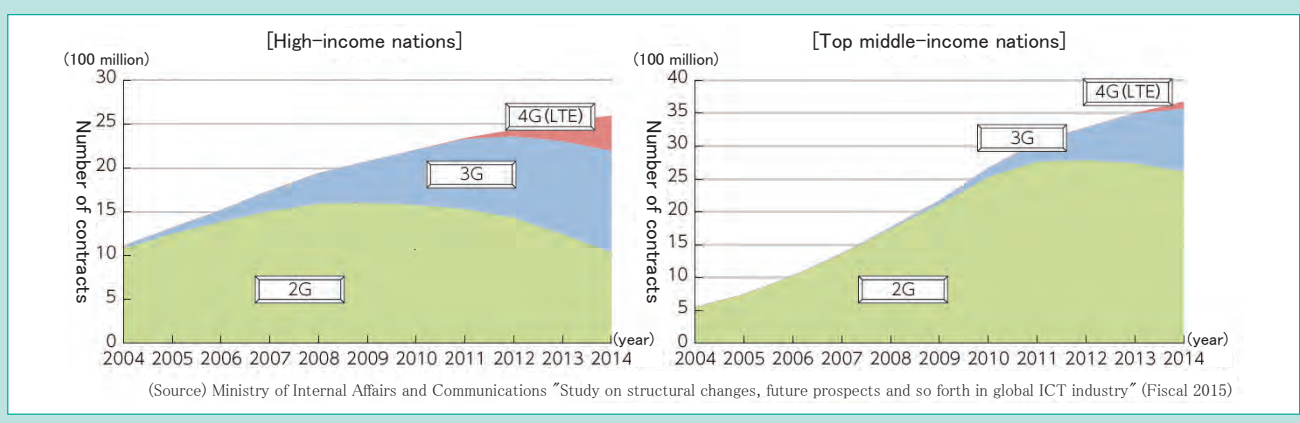

Fig. 5 Number of Contracts by the Mobile Communication in the World

4-2 Establishment of the global network

The level of telecommunication infrastructure established overseas varies dramatically by the country, as do the telecommunication carriers. While NTT docomo and NTT Communications of the NTT Group are trying to advance globalization through partnerships with the telecommunication carriers of other countries, the state of adaptation varies considerably. Therefore, we established a network adopting the global lines of both companies (Fig. 6).

These line facilities became available by expanding those already established for domestic application.

The telecommunication terminal MU-1000 communicates with the server via the mobile line of each country. Data is collected into the server from the local carrier of the partner via Access Premium for NTT docomo and Arcstar Universal One for NTT Communications. Since the parts in between are closed networks that cannot be accessed from an external source, and since MU-1000 communicates with a protocol that has proprietary telecommunication commands, any leak of information is prevented. Meanwhile, an integrated supervision system equipped with firewall functions and so forth has been installed on the Internet side

where information is disclosed from the server.

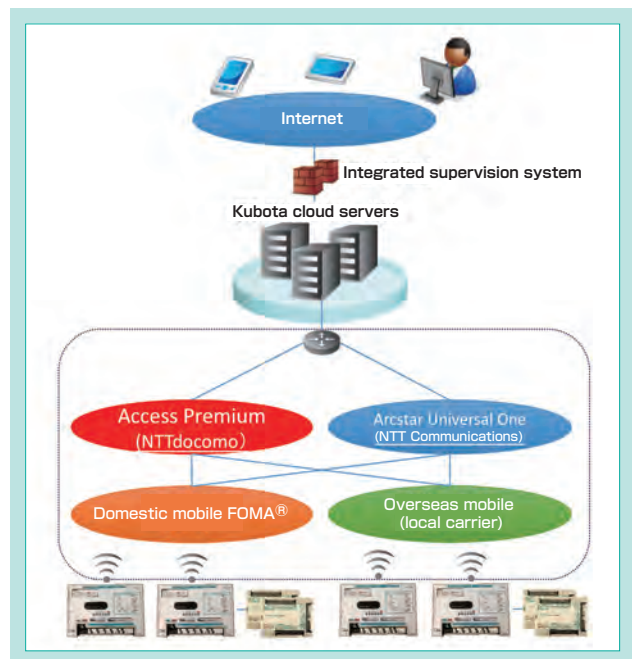

Fig. 6 Globalization of the Data Collection Networks

4-3 Telecommunication testing in Myanmar

We constructed a water treatment facility, sewage treatment facility, water distribution equipment for Japanese companies and so forth in the Thilawa Special Economic Zone in Myanmar, and carried out a confirmation test on the telecommunication status first to verify that these facilities could be remotely monitored on a 24/7 basis. Cell phones

have been rapidly taking off in Myanmar in recent years, with the telecommunication environment also being established. An investigation on the telecommunication status around the Thilawa Special Economic Zone revealed that remote monitoring was possible, even though there were some points where the service was weak.

Feature Text



IoT Solution System of Water Environment Infrastructure Facilities:K/SIS(Kubota Smart Infrastructure System)



Fig. 7 Myanmar Thilawa Map



Fig. 8 Test Equipment and Test Display

4-4 Establishment of strong security

It was necessary to increase the security for waterworks, and regular password changes are strongly recommended for the conventional login method using an ID and password especially when conducting remote operation. But the reality is that users do not change their passwords so often. Therefore, we prevented any login by impersonation by recording a registered mail address and

transmitting a one-time password to that mail address every time someone wanted to log in.

Security was further increased with measures including ensuring network security, and installing data centers at two different sites for a general-purpose monitoring server and security-enhanced monitoring server as described previously.

4-5 Reinforcement of functions on security monitoring screen

The following functions were reinforced for the security-enhanced server compared with the older general-purpose monitoring server:

4.5.1 Visualization of the entire picture with wide-area monitoring screen

With the general-purpose monitoring server, there was only the function to indicate whether there were failures on a wide-area map. We needed the water level, flow rate and so forth of many points in the water distribution system to be monitored in waterworks facilities. Adopting a list indication

of the water levels on a wide-area map as well as a wide-area trend graph enabled the user to see the correlations among facilities and increased the system's operability.

4.5.2 Improvement in human interface

A screen design with consideration given to the human interface where the system could be operated intuitively was adopted for the security-enhanced monitoring server. Importance was placed on legibility and operability, including adoption of graphics that were easy to understand.

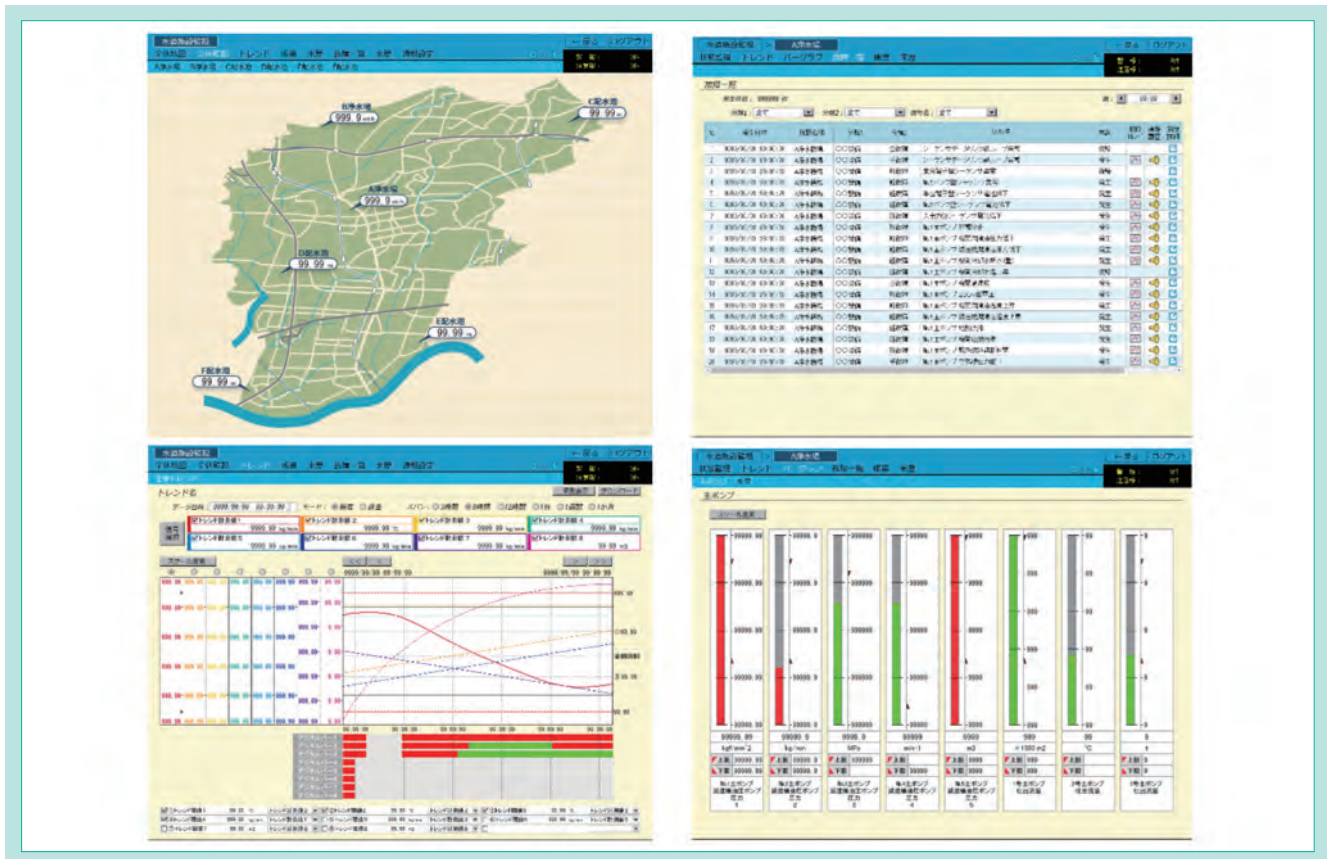

Fig. 9 Display Example of the Security-enhanced Servers

5. Conclusion

In addition to the information reported in this paper, we have developed a system utilizing types of AI technology other than telecommunication-related ones, including 4G introduction through our partnership with the NTT Group. Our goal is to solve the troubles of municipalities such as prevention of secondary disasters for facility supervisors through early measures and disaster prevention at facilities by utilizing weather prediction and so forth. We also wish to help our customers reduce life cycle cost by extending the lifetime of machinery with big data analysis on operating conditions and failure phenomena accumulated in the past.

Furthermore, private companies can also utilize our system for purposes including monitoring of overseas effluent treatment facilities from Japan. Especially in emerging countries where technical support is needed, the cost and time for visiting the country can be minimized.

At present, we are also developing telecommunication terminals that are built into the equipment in order to have all water, environment and electric products connected to the IoT. We hope to earn the trust of our customers, and have them say, "we can leave everything related to our water and environment infrastructure to the Kubota Group to take care of on a 24/7 basis."

References

- 1) Kawakatsu, Togawa, Matsue, and Sueyoshi: "Internet Monitoring System for Pumps," KUBOTA Technical Report No. 48, pp. 28-33, December 2014
- 2) Ministry of Internal Affairs and Communications: "Trend Analysis for ICT Industry in the Generation of IoTs," Fiscal 2016 White Paper Information and Communications, pp. 80-84, July 2016
- 3) Ministry of Internal Affairs and Communications: "Study on structural changes, future prospects and so forth in global ICT industry," Fiscal 2015 White Paper Information and Communications, Annotation 6, July 2015

Development of Submersible Sewage Motor Pump for China (KS-J Type)

Water & Environment R&D Dept. I / Pump Systems Dept. / KUBOTA Sanlian Pump (Anhui) Co., Ltd.

In recent years in China, a country that is seeing remarkable economic development, the amount of domestic and industrial sewage has been increasing, along with the progress of urbanization and industrialization and with the increase in scale of industrial activity. Therefore, there is increasing demand for water processing and sewage transfer equipment. Due to a greater need to move sewage and increases in environmental budgets, organizations are seeking to

reduce their running costs and have submersible sewage pumps that are reliable. We developed a submersible pump with a good performance and reliability in order to respond to market demands and also to aim at business expansion in the Chinese market.

【Key Word】

Sewage Market in China, Submersible Sewage Motor Pump, High Efficiency, Passage Diameter, Fluid Analysis

1. Introduction

The sewerage market in China used to be comprised mainly of infrastructure in large cities such as Beijing and Shanghai. However, the Chinese government has now specified the establishment of such infrastructure in rural areas as a future policy, and it is expected to actively implement this in concurrence with the urbanization of agricultural areas. This means that there will be growing demands in the sewage treatment market and sewage transfer market, indicating that demand for sewage pumps will also grow. In this sewage pump market, the tendency for operators to seek the high-quality, high-performance products of foreign, globally well-known Western manufacturers is strong and their share is relatively large even though they are expensive, besides the inexpensive products of local Chinese manufacturers. In order to expand our share in the Chinese sewerage

market, we must provide submersible pumps with a quality and performance that is equivalent to or better than the products of these foreign manufacturers.

Meanwhile, Kubota founded KUBOTA Sanlian Pump (Anhui) Co., Ltd. (KSP) (Fig. 1) in Anhui Province and is working on pump manufacture and sales for domestic and international destinations. The major products of KSP have been the double-suction volute pump for waterworks and steel markets. But KSP decided to develop a submersible pump to serve as one of its two major pillars and in this way attempt to enter the sewerage market. Kubota and KSP therefore worked jointly to develop new submersible pumps with high quality, high performance and price competitiveness which were superior to the products of competitors (Fig. 2).



Fig. 1 Kubota Sanlian Pump Factory



Fig. 2 Submersible Sewage Motor Pump (KS-J Type)

2. Development concepts and target values

2-1 Development concepts

With the target set as the Chinese sewerage market and competitors as the foreign manufacturers, we developed a total of 15 frame numbers (Fig. 3). It was especially necessary that the passage diameter was made large in order to prevent the sewage pump from being clogged with foreign matter and ensure a good performance. However, efficiency deteriorates as the passage diameter gets larger, and we had to strike a balance between these two contradicting characteristics.

In this development, we adopted the following four development concepts:

- [1] Balance between high pump efficiency and passage diameter
- [2] High reliability
- [3] Competitive price
- [4] Short delivery period

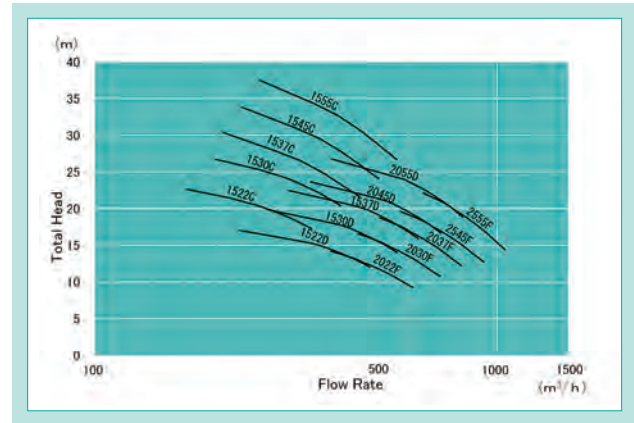

Fig. 3 Range of Specifications of New Models

2-2 Goals and development specifications

We determined the specifications based on the above development concepts (Table 1), and set out the following goals:

- [1] Balance between pump efficiency at the top level of the industry and passage diameter of 76 mm, which is sufficiently large for a sewage pump
- [2] High reliability (Japanese quality) with adoption of Japanese parts for important sections including bearings and mechanical seal
- [3] Lightweight and compact design to ensure price competitiveness against foreign manufacturers
- [4] Balance between minimum stock of parts and shortest delivery period by adopting common parts among the developed series

Table 1 Specifications of New Models

Name	Removable submersible pump
Impeller	Closed-type impeller
Number of blades	2
Nozzle size	150 mm, 200 mm, 250 mm
Motor output	22 kW~55 kW
Passage diameter	76 mm or larger
Protective device	Water leakage detector/Thermostat

3. Technical issues to be solved

The characteristics of the submersible pumps made by foreign pump manufacturers with a large share in the Chinese sewerage market included the following: [1] high pump efficiency while having an impeller shape with a large passage diameter which helps to prevent clogging with foreign matter, [2] high reliability and durability achieved by incorporating the experience and

know-how of the global pump manufacturers, [3] high price competitiveness due to mass production effect, and [4] short delivery period of around 2 to 3 months after ordering.

In order to defeat the foreign manufacturers whose products had such characteristics, we had to clear the following technical hurdles:

[1] Balance between high efficiency and ensuring a large passage diameter

While the efficiency tends to improve as the number of blades in the impeller increases, it becomes more difficult to ensure a sufficiently large passage diameter. In this performance development, we adopted a two-blade structure to ensure a passage diameter of 76 mm (3 inches) or larger, which was required for the Chinese sewage market. We thus needed to develop a fluid model for two blades, and it was quite difficult to improve the efficiency of this system (Fig. 4).

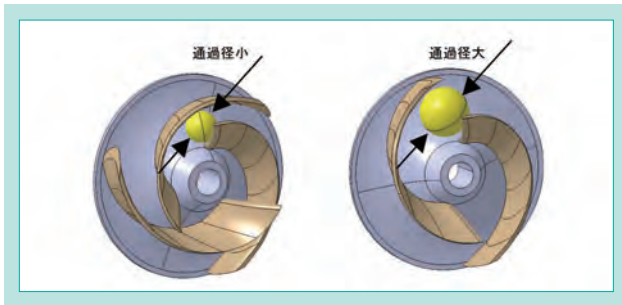

Fig. 4 Three-blade (Left) and Two-blade (Right)

[2] Durability

Since the sewage inflow varies depending on the time, submersible sewage pumps have to operate for long periods while frequently undergoing startup and stopping operations. Although we could expect there to

be a buffer effect on fluctuations in sewage inflow over time by increasing the pit capacity, this would result in higher civil engineering cost and thus lower price competitiveness when the peripheral facilities to the pump were included. It was therefore important that the pump was capable of operating with a high startup frequency so that the pit capacity could be minimized. To address this, we needed the pump to be durable enough not to have failures or quality defects even when it was subjected to frequent, repetitive startup loads.

[3] Improvement in price competitiveness

We had to improve the price competitiveness while keeping the quality at a level equivalent to or better than the high-quality, high-performance pumps of foreign manufacturers. To solve this issue, we had to reduce the costs for the pump with a lightweight and compact structural design.

[4] Shipment with short delivery period and stock reduction by using common designs

While it was necessary to retain a certain amount of stock in order to achieve shipments with a shorter delivery period compared with the competitors, it would also result in an inventory risk. We had to create a balance between shipment with a short delivery period and stock suppression by adopting common parts among the products in the series so that the inventory risk could be minimized.

4. Developed technology

4-1 Balance between high efficiency and ensuring a large passage diameter

4.1.1 Process of developing a fluid model

To develop impeller models achieving both efficiency and a sufficient passage diameter, we implemented model development while assuming the use of a two-blade type which had the minimum number of blades and which made it easy to create a fluid-load balance.

We had to repeat many evaluations in order to create a model with the fluid loss minimized to the extreme compared with the conventional model and a good fluid-load balance based on our assumption. It was decided that the model shapes for the evaluation were to be managed in unitary using the same 3D data in each of the design, analysis and prototyping processes. This allowed us to implement evaluation with high precision and speed up the cycle of design, analysis and prototyping.

To further accelerate the development process, we decided to utilize a 3D printer and manufacture the impeller prototype in a short period. We also came up with special evaluation equipment (Fig. 5) so that the resin impeller manufactured in a 3D printer could be used in operation and evaluated in a short period.

Thanks to these measures, we were able to reduce the number of days until the completion of evaluation for one model after designing to approximately one-third of the conventional period.

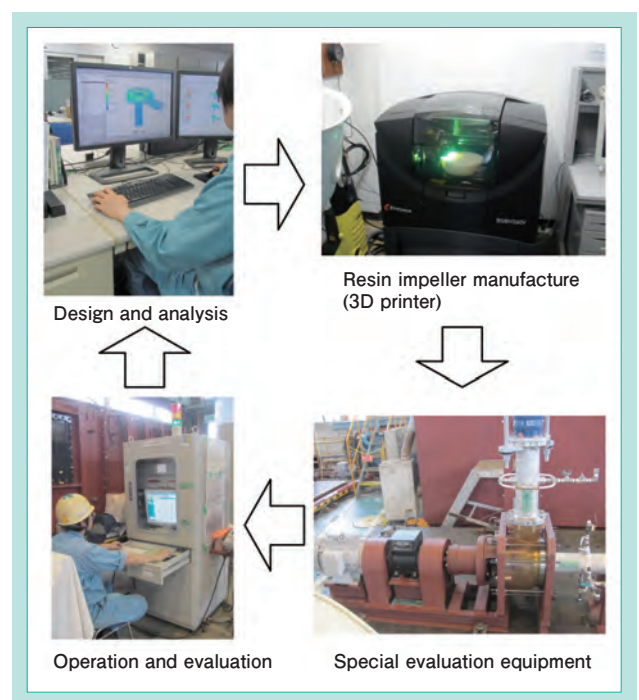

Fig. 5 Development Process

4.1.2 Development of high-efficiency impeller

(1) Meridian plane design

turbulent flow tends to occur if the meridian plane shape (the plane formed by a revolved projection of the blade shape along the central axis) on the passage turns abruptly from the axial direction to the radial direction at the impeller inlet. To lead the flow of sewage smoothly, we assigned the blade inlet line at a more upstream point while giving three-dimensional twists and designed the optimal inlet shape to ensure sufficient passage diameter while confirming performance with fluid analysis (patent pending).

(2) Design with increased blade thickness

Since there were two blades, the passage between them is large and the pump is prone to having disturbances in flow. We therefore came up with a design in which the blade thickness was changed dramatically based on airplane wings, and straightened the streamline between blades to reduce the fluid loss (Fig. 6). We also designed a shape so that the passage diameter was ensured. This was an unconventional design for increasing the blade thickness (patent pending).

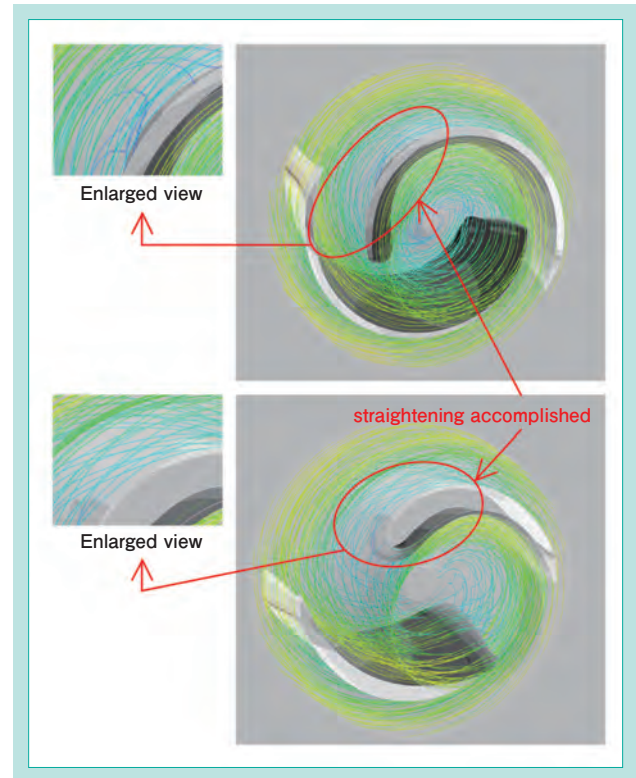

Fig. 6 Comparison of Streamlines Between Conventional Design (Top) and Thick Design (Bottom)

4.1.3 Development of low-loss casing

While the casing had been designed by separating it into the volute chamber part and the nozzle part in our conventional methods, we made it so that the incorporated 3D shape could be prepared in a short time by only specifying the values for several parameters.

We selected the four parameters with the largest contributions (basic diameter, volute chamber width, throat area and volute chamber area change ratio) (Fig. 7), and varied each parameter in three different levels to fit them into an L9 orthogonal table. We implemented fluid analysis for different combinations and evaluated the sensitivity of each parameter against loss. Based on the results, we elucidated the optimal combination of parameters and minimized loss.

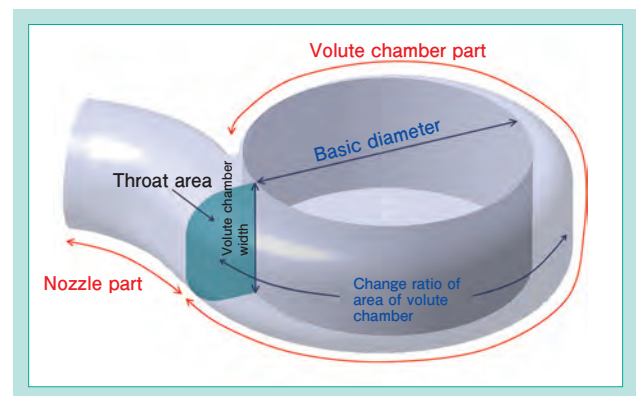

Fig. 7 Representative Design Parameter of Casing

4.1.4 Evaluation of pump performance

The pump performance was measured and evaluated using actual-size diameters of 150 to 200 mm. In this way, we confirmed that the pump efficiency was improved from that of the conventional Kubota machine by 5% (Fig. 8). We also measured the fluid load applied to each bearing during operation at the same time. Due to the reduction in fluid loss achieved with flow rectification, the fluid load decreased by 20 to 30% from that of the existing model, indicating that we were able to improve reliability and durability. Regarding the passage diameter, we confirmed that a ball with a diameter of 76 mm passed through the verification machine built in actual size.

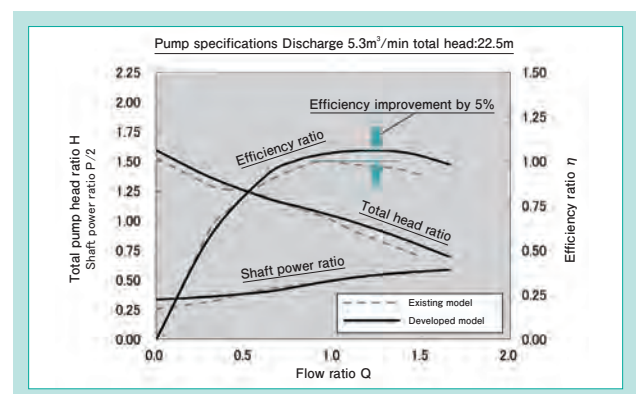

Fig. 8 Performance Curve

4-2 Confirmation of durability

4.2.1 Endurance test (repetitive startup and stopping test)

The startup current and torque are high at pump startup, and the loads applied on the motor, bearings and so forth also increase. Since the amount of sewage inflow fluctuates for submersible sewage pumps depending on the time, they inevitably repeat startup and stopping operations, and must endure such repetitive startup loads. In this endurance test, we implemented a repetitive startup test by assuming the total startup count within a period of use of several years. We also implemented a test to start up and stop the pump a few dozen times per hour with the assumption of a pump pit with a small capacity (Fig. 9).

The items to check and judgment criteria were as follows:

- [1] Fatigue fracture in motor
There should be no dielectric breakdown or abnormal heating. The motor performance should not be affected adversely.
 - [2] Mechanical seal leakage
There should be no damage, oil leakage or water leakage.
 - [3] Impeller bolt loosening
The bolt shall not become loose.
 - [4] Wear in impeller liner
The impeller liner part should not become worn.
- After implementing the specified repetitive startup and stopping tests under the above conditions, we disassembled the pump and checked items [1] to [4].

The results confirmed that the pump presented no problem in any of the check items (Fig. 10).



Fig. 9 Taking Out the Pump After Endurance Test

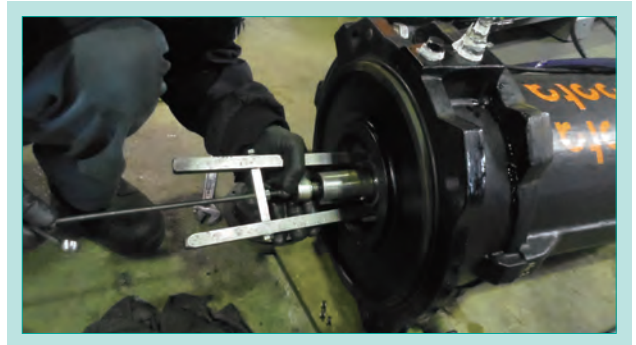

Fig. 10 Disassembling the Pump After Endurance Test

4-3 Improvement in price competitiveness

4.3.1 Lightweight and compact design

To improve the price competitiveness of the developed machine, we needed to achieve a lightweight and compact structural design. The specific measures are listed below:

- [1] The motor size was reduced from the conventional machine by increasing the heat radiation effect with diameter reduction and elongation of the motor in axial direction, and raising the insulation class by one level.
- [2] With the conventional machine, there was room for storing a cable at the top of the pump. Compared with this, by utilizing the top of the immersion detection space of the bearing housing in the developed machine as the space for cable storage, we were able to eliminate the cable cover and reduce the number of pump components.
- [3] High-efficiency and compact fluid model design resulted in reduction in motor output and its casing size.

As a consequence of these measures, the weight was reduced nearly to half of the conventional machine (Fig. 11).

We also took measures to prevent serious pump failures by adopting protective devices (Thermostat and Water leakage detector) as standard equipment while keeping the functional aspects at the same level as the conventional machine.

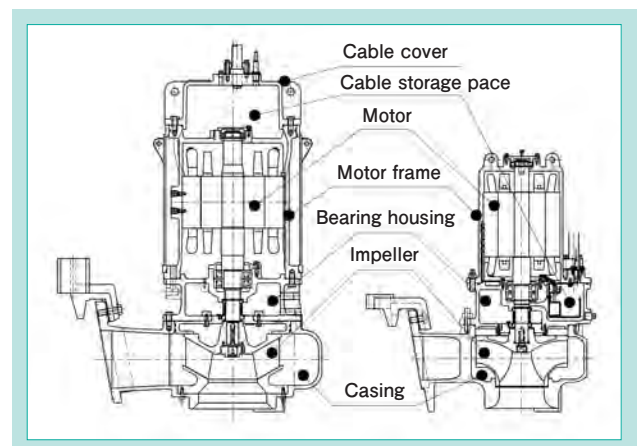

Fig. 11 Conventional Model (Left) and the Development Model (Right)

4-4 Short delivery period

4.4.1 Common design

To ensure shorter delivery periods than our competitors and suppress stock at the same time, we adopted common designs for the parts among the developed series. Common parts were used for major components and the number of drawings was minimized for the series so that the number of wooden patterns and amount of parts in stock were minimized. As a specific example, with unification of the motor assembly and casing attachment diameter “A” and impeller attachment shaft diameter “B,” we were able to use the same one type of motor assembly as a common part for each output, regardless of the casing discharge diameter and impeller shape (Fig. 12). We also adopted an impeller, casing and cable as common parts to ensure a short delivery period and reduce stock.

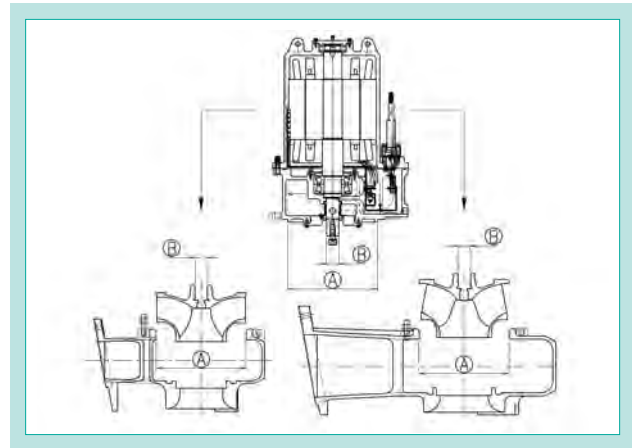

Fig. 12 Sharing of Motor Assembly

5. Conclusion

Sales of the removable submersible pumps we developed in this project began in China in April 2016, and good effects have begun to appear in terms of first-time orders (Fig. 13), increased number of inquiries and so forth mainly for treatment plants and relay pump stations.

The outcomes produced with this product are summarized as follows:

- [1] Pump efficiency was improved by 5% compared with the conventional model, while at the same time ensuring a passage diameter of 76 mm or larger which was important for submersible pumps.
- [2] It was confirmed that the pump could operate stably even under severe operating conditions with frequent pump startup and stopping by ensuring the quality of important parts.
- [3] A lightweight and compact design was achieved by dramatically reviewing the efficient motor cooling structure and cable connection structure.
- [4] Short delivery period and suppression of stock were ensured simultaneously by adopting common parts in the design of the developed series.

Furthermore, as a derivative product utilizing these outcomes, we released a fiberglass reinforced plastic (FRP) prefabricated pump station (Fig. 14). This is a product which incorporates the set of pumps, piping, valves and so forth inside the FRP frame, and it is an equivalent product to the manhole pump popularly used in rural areas of Japan. Since sewage infrastructure will be established in rural areas in China, large demand can be expected for this product.

In the future, we plan to roll out the developed pumps widely throughout Japan and Southeast Asia in addition to the sewage market of China in order to disseminate the Kubota brand in the water and environment fields of the world.



Fig. 13 Shipment of First Order



Fig. 14 FRP Prefabricated Pump Station

Literature

- 1) Susumu Terada, Design and Drafting for Volute Pumps, Rikoh Tosho, p. 114, 1967

Development of Strategic Backhoe for China

Construction Machinery R&D Engineering Dept.

Heretofore, when Kubota introduced a new backhoe into a developing country, we made only minor changes based on a conventional model for developed countries. It became impossible for us to maintain a competitive edge by making only minor changes, as in the past, because there is now increased competition as the Chinese market expands. So, we thoroughly researched the Chinese market and found : 1) the swing and dozer functions that are characteristic of a mini backhoe

(MBH) are used less frequently as the weight of the machine increases, and 2) a longer refueling interval has become a big selling point due to the relationship between the machine owner and operator that is peculiar to China. In this paper, we introduce strategic backhoe that incorporates those research results for China.

【Key Word】

China, Backhoe, Swing, Feed Interval, Dozer

1. Introduction

Large models (20-ton machine weight classes and above) had been the mainstream when Kubota first entered the backhoe (BH) market of China in the beginning of the 2000s, and the market for mini backhoes (MBHs), which were small types (less than 8 tons) and the key products of Kubota, had only begun forming. In addition, a major power shovel manufacturer from South Korea had already introduced its 5-ton and 7-ton machine weight class products as its lightest BH models and was practically dominating the market.

Under such market circumstances, Kubota founded a marketing company for construction machinery in Shanghai (2003). We established a marketing network over the entire area of China and at the same time started exporting 1.5-, 3.5-, 5- and 8-ton MBHs manufactured in Japan. Although sales stagnated in the beginning in the provinces around the eastern coast where the South Korean manufacturer had already dominated the market, they began to grow as MBHs were introduced mainly from the inland areas.

Even though our strategy worked and the foundation for our construction machinery business in China had been established, challenges that needed to be tackled

for further business expansion were also revealed. The greatest issue was the price. South Korean manufacturers had already moved their production plants to China and achieved prices lower than those of Kubota by 20% or more with local purchasing of parts, reduced functions and so forth. Compared with this, Kubota was exporting its high-function, high-additional-value products developed for Japan, Europe and the U.S. with few changes. It was utterly impossible to compete with South Korean manufacturers in price.

The next challenge was the difference in how the products were used. Most users who purchased MBHs in China were individual owners that used a “rental with an operator” system, where they employed operators and hired them out along with machines. They tried to recoup the funds they had invested in machine purchases as quickly as possible and thus had extremely high operating rates for the machines and applied high loads on them. The owners also did the refueling by themselves as they made the rounds to the sites instead of allowing the operators to handle the expensive fuel. These were some of the unique circumstances in China that were revealed.

2. Challenges in Chinese market and our proposed measures

2-1 Achieving a low price (development of KX155-5 and KX175-5, strategic machines for China)

The two major points in achieving a low price were as follows:

- [1] Establishment of a plant in China for local production, and
- [2] Development and introduction of strategic machines specialized for the Chinese market.

In 2011, KUBOTA founded a construction machinery manufacturing company (Kubota Construction Machinery (Wuxi) Co., Ltd. or “KCW”) in the province of Jiangsu in China, and it started operating the following year.

This made it possible to dramatically reduce costs by adopting local parts and so forth, while maintaining the high-quality brand which was highly reputed in the market.

We also conducted detailed market surveys and observed many sites where the machines actually operated to collect user opinions, and found out the following:

- 1) The existing machine weight of 8 tons was too large, and a weight of 7 tons was sufficient for operation.
- 2) Swing and dozer functions, which were considered important basic functions of MBHs in Japan, Europe and the U.S., were almost never used in China.
- 3) Minimizing the rear part of the machine was a point of differentiation which was considered advanced.

Since these points could not be addressed by simply modifying the conventional machines, we started developing our own strategic machines for China.

We worked to give the next-generation machine an advanced look by eliminating the swing function and

downsizing the engine for KX155-5 (Fig. 1), to create a 5-ton strategic machine for China. For KX175-5, the 7-ton strategic machine, we strove to dramatically reduce costs by eliminating the dozer function, downsizing the engine, reviewing the frame strength and so forth based on the 8-ton machine, and our efforts resulted in a weight reduction of almost 1 ton.



Fig. 1 Developed Model KX155-5

2-2 Measures to address the unique demands in China

As described previously, one of the greatest sales points in China is a long refueling interval, because most MBH owners refuel the machines themselves by making the rounds to the sites. KX155-3, the conventional model of the strategic machine KX155-5 which was introduced in China without changing the Japanese domestic specifications, had a fuel tank capacity of 64 L, which was too small for the Chinese market.

Therefore, we increased the fuel tank capacity greatly to 100 L for strategic machine KX155-5 (Fig. 2). In addition, we gave the new model a low fuel consumption by newly adopting an Eco Mode, allowing the user to simply switch to an engine rpm range with high fuel efficiency. These measures approximately doubled the refueling interval compared with the conventional model.

We also improved the durability of working parts, frame and so forth to ensure endurance under severe use in the Chinese market.

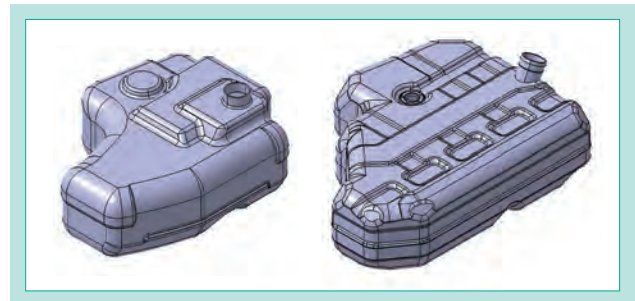

Fig. 2 Fuel Tank of Conventional Model and Developed Model

3. Conclusion

This report introduced an overview of our construction machinery business' efforts to cultivate the Chinese market.

While we often introduce an existing product first and collect information when cultivating a new market, we assume that the most important points in this case are to carefully observe how the products are used in various different sites, listen to a wide range of user opinions, and sufficiently consider the culture, history, national

traits and so forth of the country.

Although Kubota has developed strategic machines KX155-5 and KX175-5 for the Chinese market and they have received high evaluations, it has so far been able to enter only a small fraction of the entire global market.

In the future, we plan to develop new products in a timely manner while properly grasping the market characteristics and customer needs.

Installation and Operation of Solid-Liquid Separation System for Al Ansab Sewage Treatment Plant in Oman

Membrane Systems Dept./Water Engineering and Solution Planning and Sales Promotion Dept./
Water Engineering and Solution Construction Department

The Al Ansab Sewage Treatment Plant (Al Ansab STP) in Muscat, Oman, uses a membrane bio reactor (MBR) system which can produce highly treated water so that it can be reused. KUBOTA Submerged Membrane Unit™ (Kubota SMU) was applied there as solid-liquid separation equipment for the MBR system, and has been operating since 2010 with good performance. Moreover, construction work to expand the capacity of the site is proceeding to meet increasing amounts of waste water, and Kubota SMU was applied again for that expansion project. In September 2016, the installation work for Kubota SMU in four of twelve tanks was completed and it began operating. This report introduces the large-scale

MBR STP oversea which is operated with Kubota SMU, and describes problems to be solved for installing new equipment. It also mentions the solutions, and operating condition after installation work.

【Key Word】

Membrane Bio Reactor (MBR), KUBOTA Submerged Membrane Unit, Large-scale Sewage Treatment Plant, Reclaimed Water

1. Introduction

Strain is being placed on the global water supply. As a countermeasure to this, there is increasing demand for reclaimed water, which is the product of advanced treatment of sewage or industrial effluent. One key technology to meet this demand is the Membrane Bioreactor method (hereafter abbreviated as the MBR method). This is an effluent treatment technology combining biological treatment utilizing the functions of microorganisms and solid-liquid separation with membranes, and it delivers clean, treated water. There are various applications for MBR-treated water as reclaimed water, including direct use as landscape irrigation water, agricultural irrigation water, and reused waste water, and water supplied to reverse osmosis (RO) membrane treatment which can deliver even more highly treated water.

As a pioneer manufacturer, Kubota has supplied the membrane filtration equipment (Submerged Membrane Units) used in the MBR method to various destinations around the world. The number of facilities delivered to exceeds 5,000 today. In many cases in Japan, operators want to reuse effluent water within a building as waste water and so they treat it with a membrane. The treated water is recycled for cleaning and so forth in various plant effluent treatments.

We have exported our Submerged Membrane Units overseas for more than 20 years with sales offices established in North America, Europe and China, and contributed to the global effluent treatment and generation of reclaimed water. Figure 1 shows the ratio of delivery to each area based on the quantity of treated water. It shows that overseas sales account for 76% of all our sales, and that the Submerged Membrane Units are working to produce clean water all over the world and not just in Japan. Regarding large-scale MBR sewage treatment plants, we received orders for MBR systems including an order from Sakai City Sambo Sewage Treatment Plant (treatment scale 60,000 m³/day) in 2010 and Canton Sewage Treatment Plant (treatment scale approximately 160,000 m³/day) in 2015.

This report introduces the activities of Kubota at Al Ansab Sewage Treatment Plant (Al Ansab STP) in Muscat, Oman, as a case example for large-scale sewage treatment plants utilizing our Submerged Membrane Units.

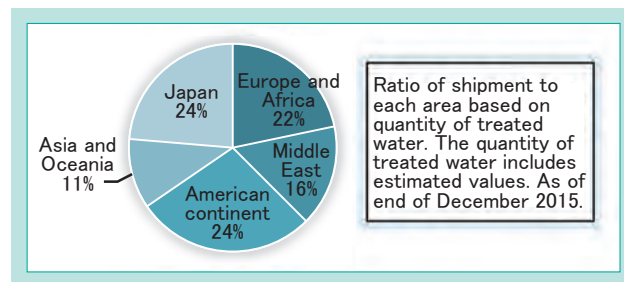

Fig. 1 Installation of Kubota SMU in the World

2. Facility expansion plan

2-1 Overview of Al Ansab STP

Al Ansab STP is a sewage treatment plant in the city of Muscat, Oman, and the MBR facility has been operating there since 2010 (hereafter referred to as the First-Term Construction). The quantity of sewage treated is 55,000 m³/day, and Kubota's Submerged Membrane Unit EK400 has been adopted. The biological treatment tanks comprise four streams, with the membrane tanks in which the Submerged Membrane Units are installed making up eight streams in the subsequent stage. MBR-treated water is supplied to the green belt adjacent to the treatment plant as irrigation water, and also used in various different applications as reclaimed water through a pipeline installed within Muscat.

As of September 2016, work was being carried out to expand the treatment plant with a plan to increase the treatment capacity to 125,000 m³/day (hereafter referred to as the Second-Term Construction). The Submerged Membrane Units were to be replaced with a model having a larger filtration area to produce more treated water. That is, the EK400 model is being replaced with the RW400 model. An outline of the Second-Term Construction is provided below:

- Replacement of all the existing Submerged Membrane Units (eight existing tanks installed with Submerged Membrane Units)

- Additional installation of membrane tanks and installation of Submerged Membrane Units (four newly installed membrane tanks)
- Additional installation of biological treatment tanks (to six from the existing four systems)
- Additional installation of related facilities including pretreatment facilities and sludge treatment facilities

Table 1 shows the design capacity and treatment systems, and Table 2 shows the design water quality. At the completion of the Second-Term Construction, the quantity of MBR-treated water to be recycled will also increase and contribute greatly to the water resource measures of Oman.



Fig. 2 Overview of MBR System

Table 1 Design Capacity and Configuration of MBR System

Item	Design capacity m ³ /day	MBR system		
		Anoxic tank + aerobic tank	Membrane tank	Kubota Submerged Membrane Unit
First-Term Construction	55,000	Four streams	Eight streams	EK400
Second-Term Construction	125,000	Six streams	Twelve streams	RW400

Table 2 Design Water Quality

Item	Unit	Inflow sewage	MBR-treated water
BOD	mg/L	256	5
TSS	mg/L	250	5
T-N	mg/L	35	8
NH ₃ -N	mg/L	25.2	1

2-2 Reasons why Submerged Membrane Unit was selected

As the filtration membrane systems of the existing facility were to be replaced in the Second-Term Construction, in terms of construction cost and period it was important that the filtration membrane area was effectively increased while putting the existing facility to maximum use. Since EK400 and RW400 are highly compatible with each other, the existing foundation for Submerged Membrane Unit installation and many of the pipes can be utilized without modification while increasing the filtration area dramatically. In addition, the specifications of the necessary operating equipment such as the blower are identical for EK400 and RW400, indicating that the plant can continue to use the existing operation procedures and that no large changes in the control system are necessary. Therefore, the construction period can be drastically reduced.

Furthermore, KUBOTA Submerged Membrane

Units have been delivered to more than 5,000 different locations in the world, and KUBOTA's products also have a track record of stably supplying reclaimed water at Al Ansab STP since 2010 when actual operations started. We consider that our Submerged Membrane Units were selected thanks to the track record being recognized over the world, and the after-sale follow-up at this facility and compatibility with the existing facility being evaluated highly.

In addition to sales of filtration membrane systems in this project, we are providing support for updating to a more suitable treatment facility with a review to designs and proposals on operation methods based on the operating conditions of the sewage treatment plant in the past. Since we have also worked on constructing sewage treatment facilities in Japan, we can propose construction processes by utilizing our knowledge.

3. Application of KUBOTA Submerged Membrane Units in expansion plan

3-1 EK400 and RW400

RW400 has a filtration membrane area per unit system installation area approximately 1.8 times that of EK400, and is capable of dramatically increasing the filtration capacity of the existing membrane tanks. The difference between these two models lies in the size of a filtration membrane called the membrane cartridge which is installed in each membrane separation equipment. Table 3 shows the specifications of each membrane separation equipment and Fig. 3 shows the structure of RW400.

A Submerged Membrane Unit conducts filtration inside the activated sludge as it is installed in a membrane tank. Some 200 membrane cartridges are fixed in equal intervals in each of the upper

and lower membrane modules to generate clean, permeate water. The permeate water is ejected from the equipment through the attached manifold. Diffuser are retained at the bottom of the equipment so that the air released from the diffuser forms upward sludge flow and constantly cleans the membrane surface.

Table 3 Specification of Kubota SMU

Item	Unit	EK400	RW400
Number of membranes	cartridge/unit	400	400
Filtration area	m ² /unit	320	580

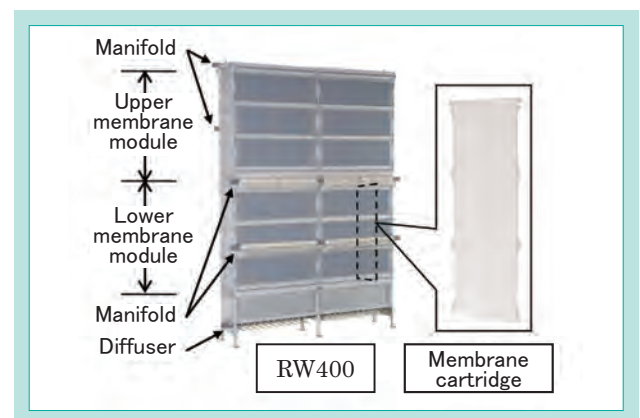

Fig. 3 Structure of RW400

3-2 Utilization of existing facilities

RW400 is a large model which was developed with the possibility of updating from EK400 within sight. Not only the construction cost but also the construction period can be reduced dramatically if the existing facilities can be put to maximum use. Here, the issue is to ensure compatibility in

connection parts between Submerged Membrane Units and the existing facility. And there are three such issues: (1) utilization of installation foundation, (2) utilization of air piping, and (3) utilization of permeate water piping.

(1) Utilization of installation foundation

A Submerged Membrane Unit is fixed at the bottom of the tank with anchor bolts. Since the size of the anchor bolt, positions and quantity are identical between EK400 and RW400, utilization of the existing foundation can be expected. However, it had been six years since operations were launched at the existing facility, and there were concerns about a deterioration in the foundation components. Therefore, we checked the conditions of the foundation, and were able to complete the installation work in a short period by reusing what could be reused without repair. Figure 4 shows an example of the foundation components.

(2) Utilization of air piping

The diffuser for a Submerged Membrane Unit are connected to a blower via air piping to supply air to the membrane surface. The air which is supplied from the blower is sent uniformly to the Submerged Membrane Unit via the header pipe installed on each membrane tank. The positions of the diffuser connection and the diameters of the pipe are identical between EK400 and RW400 so the existing air piping can be used without modification. Especially in this facility, a removable coupling was used for this connection part, and it was decided that this coupling would also be reused.

(3) Utilization of permeate water piping

The manifold of a Submerged Membrane Unit are connected to the permeate water piping to discharge the permeate water. Since the location of a permeate water pipe connection is different between EK400 and RW400, the permeate water pipe of the membrane tank needed to be replaced. However, the permeate water pipe work was minimized by utilizing the permeate water header pipe installed outside the tank without modification.

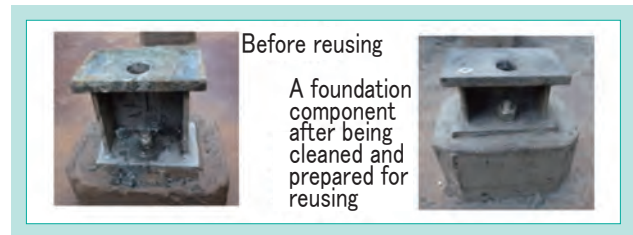

Fig. 4 An Example of Basement

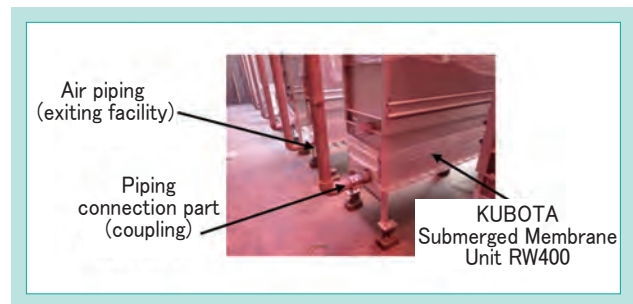

Fig. 5 Reuse of Air Piping

3-3 Utilization of gravity filtration facility

This facility adopted gravity filtration which utilized the water level difference between the membrane tank and permeate water piping, and thus required no pump for filtration. However, the height of RW400 is approximately 80 cm larger than EK400 and we needed to solve the following issues in order to ensure a sufficient water level difference or filtration driving force:

- (1) A water depth necessary for gravity filtration could not be ensured if RW400 was applied to the existing tank.
- (2) Due to the difference in the location of the manifold connection, the permeate water piping needed to be installed at a higher position.
- (3) The filtered water piping penetrated the tank wall and the part that penetrated the wall could not be replaced. This generated a difference in installation height between the permeate water piping in the tank and the piping that penetrated the wall, and it was feared that air accumulation might inhibit filtration.

As measures against these issues, we made the following proposals:

- (a) Raising the water level for the membrane tank by approximately 100 mm

(b) Installing an air vent valve on the permeate water piping.

We were able to eliminate the air from inside the permeate water piping before operation by installing an air vent valve. This valve is closed during filtration to form conditions favorable for filtration. Adoption of these proposals resulted in the plant being able to utilize the piping penetrating the wall and the permeate water header pipe outside the tank without modification.

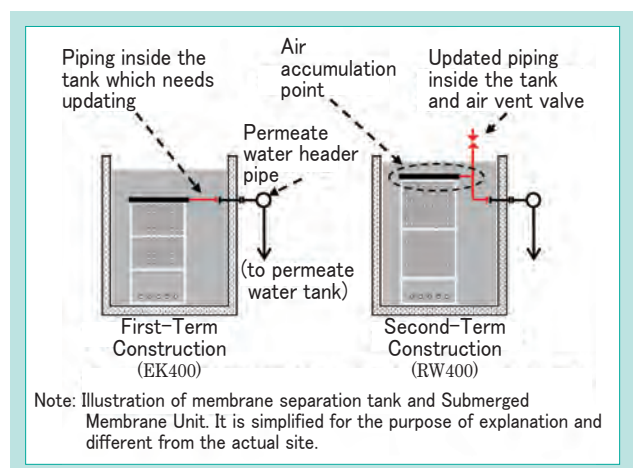

Fig. 6 Piping Modification for Gravity Filtration

4. Developments in operation

Construction was carried out in each membrane tank, and a performance test was subsequently conducted using sludge. The quantity of permeate water, filtration pressure and quality of permeate water were checked in the performance test. Figure 7 shows an example of the operation data. As shown in the figure, both the quantity of permeate water and filtration pressure were stable. As the quality of permeate water, suspended solid

content (SS) was measured, and good results indicating 1 mg/L or less, which is the lower limit measurement value, were obtained. As of the end of September 2016, the performance test has been completed for four out of twelve membrane separation tanks in total, and the tanks have been successively put to practical use to help generate reclaimed water.

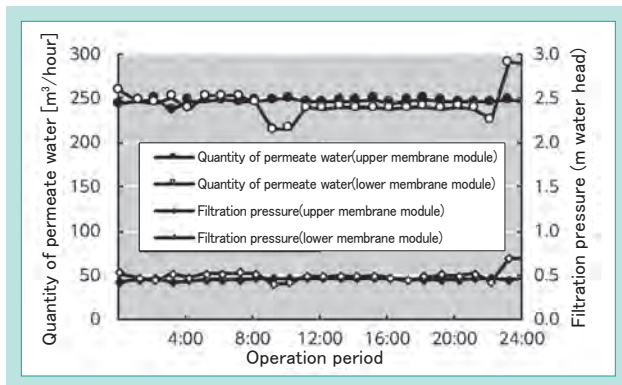

Fig. 7 Operation Data with RW400



Fig. 8 Overview of Membrane Tank

5. Conclusion

This report introduced Al Ansab STP in Oman as a case example of a large-scale sewage treatment plant using our Submerged Membrane Units. At present, it is going through the Second-Term Construction, with installation of Submerged Membrane Units complete and actual operation started in four out of the eight existing membrane tanks (as of the end of September 2016). In the future, when construction is completed for all eight existing membrane tanks, four more tanks are to be installed additionally. The operation case example in this facility showed the large degree of adaptability of Submerged Membrane Units and the MBR method

in large-scale sewage treatment plants, and indicates that they can be rolled out globally. Kubota plans to further substantiate the after-sale follow-up activities in addition to verifying the quality and performance of the equipment to accumulate more knowledge and experience from this case example.

The MBR method, one of the key technologies for eliminating the issue of water shortages, is expected to become increasingly popular in the world. We hope to roll out our Submerged Membrane Units globally and try to help solve water issues.

The Introduction of Kubota Research & Development Asia (KRDA)

1. Introduction

In recent years, ASEAN countries have been undergoing rapid modernization of agriculture in concurrence with their economic development, with Thailand being the leader in this development. Kubota aims to further reinforce research and development capability which lies at their core as a manufacturer and speed up product development to support the rapid expansion in ASEAN business. To this end, Kubota founded Kubota Research & Development Asia (KRDA), to reinforce product development system in Engineering Department of SIAM KUBOTA Corporation (hereafter as “SKC”) located in Thailand.

KRDA has the following two roles:

- 1) To properly grasp the market situation (users, crops, processes, natural conditions, etc.) and introduce products with competitiveness into the market through speeding up the development of products suited to the market and improving their quality.
- 2) To away from centralized system of product development in Japan, employ and nurture excellent local human resources and try to reinforce workforce involved in product development.

Trying to create products trusted by the most customers in ASEAN as its first step, KRDA will contribute to agriculture development in ASEAN by working to achieve “Global Major Brand Kubota,” ensuring it is the brand capable of making largest contributions to society as a result.

2. Overview

This is the 38th year since SKC launched production and sales of agricultural diesel engines in Thailand. SKC has helped to promote mechanization and developments in Thailand agriculture through its production, sales and service activities related to agricultural machinery since its foundation. Modernization of Thai agriculture has rapidly advanced especially in the last ten years. And specifying Thailand as a strategic base for agricultural machinery production in Southeast Asia, Kubota became the only agricultural machinery manufacturer which has complete integrated production system covering steps from casting, processing and assembling of engines, assembling of hydraulic parts, assembling of tractors and combine harvesters, and also designing, developing and assembling of implements and attachments installed on these main machines.

To further reinforce the market-in product development for the markets of not only Thailand and its surrounding countries but also all other ASEAN countries, we founded KRDA as a base to improve the development capabilities of the entire Kubota Group in Thailand, where is the center of ASEAN agriculture and having rich pool of excellent human resources. The purposes of the foundation were [1] to establish a safe workplace environment, [2] to improve the efficiency in research and development, [3] to protect confidential information and intellectual properties, and [4] to

reinforce research and development capability by further enhancing design and development skills of all staffs.

KRDA premises contain [1] an office building for design and research employees, [2] a research building where prototype machines are assembled, [3] a basic traveling test ground and basic test field to check performance of assembled prototype, [4] a bench test building to conduct axle/PTO output measurements for tractors, combine harvesters and so forth and endurance tests for tractor implements, and [5] a circular rough road test course to conduct unmanned rough road traveling tests while taking measurements on stress, vibration and so forth in various parts. Since all processes except for the performance test using actual crops, including research and development planning stages, design, prototyping, basic performance test, and endurance test, could be implemented within KRDA for various different agricultural machines, the development efficiency can be improved dramatically. It is located near SKC Navanakorn Office, home to KRDA’s Sales and Marketing Division at the edge of the Navanakorn Industrial Estate, and unmanned operation is possible on a 24/7 basis in [4] the bench test building and [5] circular rough road test course. Figure 1 shows the overall view of KRDA.

Outline of KRDA

- Name of facility: Kubota Research & Development Asia
- Date of foundation: May 19, 2016
- Address: 101/123 Moo 20 Navanakorn Industrial Estate, Khlongnueng, Khlongluang, Pathumthani
- Lot area: 22,400 m² (14 rai, a unit of area in Thailand)
- Building facilities: Office building, research building, basic traveling test ground, basic test field, bench test building, and circular rough road test course
- Business description:
 - [1] Minor changes and design changes for SKC production models (tractors, combine harvesters, etc.)
 - [2] Regionally limited products, implements, attachments, etc. for ASEAN countries



Fig. 1 Overall View of KRDA

3. Records of product development at KRDA and future prospects

3-1 Situation of agriculture mechanization in ASEAN countries and case example of product development

KRDA has an important role to “advance mechanization through the construction of an integrated system for mechanization of agricultural processes (soil preparation, seeding and transplanting, intermediate management, harvesting and transport) suited to the various crops in ASEAN countries (rice, sugarcane, cassava, corn, soybean, wheat, palm, rubber, etc.)” In agriculture, crops, cultivation methods, and soil which functions as the basis for cultivation vary by the region. It is also true that many of processes are still done manually. While the needs for mechanization of these agricultural processes are growing, lineup of products suited to the diverse processes varying by countries and crops is still insufficient.

At present, when considering by crop type and process in ASEAN countries, the mechanization rate remains low for seeding, transplanting and harvesting in a dry field, while it is growing in soil preparation process in paddy field using power tillers and tractors and also transplanting and harvesting by transplanter and combine harvesters respectively.

Although we have promoted developments of

various implements for paddy rice crops (rotary, disc plow, disc harrow, front dozer, etc.) in the past, lately we have also been devoting efforts to the development of dry field implements. A recent example is an implement to transplant seedlings of cassava (Fig. 2). It can be attached to a middle-size tractor, which is the most popular model in Thailand for working in rice paddy fields and dry fields, and is a semiautomatic-type implement which requires an operator to ride on. Compared with manual work, it improves work efficiency by approximately four times, and enhances transplanting precision (straight travelling, perpendicularity, space between seedlings, space between rows, etc.). These result in better growth conditions. The survey result on yield with actual users showed that the yield had increased by approximately 10 to 50% per unit area.



Fig. 2 Planting by Cassava Planter and Result

3-2 Future prospects

Many cases of mechanization of agricultural processes for crops unique in ASEAN as described above are those even Kubota has never experienced in the past, or have no precedents in mechanization anywhere in the world. Even if there are cases of mechanization, the large machinery popular

in Europe and the U.S. is often not suitable for ASEAN region in terms of size and price. In development, it is therefore important to determine how mechanization can be achieved for processes that are currently done manually while considering the diverse local characteristics.

The ASEAN market has an important global position and dramatic growth is expected there in the future. There are many development themes for KRDA that urgently need to be addressed. The immediate issue is the mechanization of seeding, transplanting and harvesting processes for various dry field crops as described previously. Development should be promoted vigorously for a multi-seeder capable of seeding different crops including rice, beans, and corn, and harvesters for cassava, sugarcane and so forth.

Meanwhile, local compatibility and endurance

tests are implemented by bringing the tractor, combine harvester or transplanter designed by the engineering departments of KUBOTA into an actual field and soliciting the cooperation of actual users. These tests are also important responsibilities of KRDA, even though they require steady work to confirm the results over several months to years. We will promote measures so that KRDA will in future have the development capability to handle the design and research on such main machine themes related to tractors and combine harvesters.

4. Conclusion

The mission for KRDA is to address the problems of aging and shortage of labor in rural areas of ASEAN countries that are occurring along with their economic development. KRDA must also take social responsibility as an agricultural machinery manufacturer to achieve further developments in agriculture itself, so that the customers living can be improved. Such customers include [1] custom-hiring contractors (who providing field work service) who purchase agricultural machinery and [2] client customer (who hire contractors for doing field work on their farm land) who own the farm land. KRDA's developments should result in increasing of income from custom-hiring for contractors and also increasing in income for client customer from higher crop yield and quality which is result from higher-efficiency and higher-precision work using its

agricultural machinery.

The product development policy is "Satisfy user needs & Create KRDA seeds." Specifically, it is to satisfy the demands of customers who "want to use certain machines" and be capable of proposing "this kind of useful process (machine)" to the customers.

The common concept for development themes on products for the ASEAN market is "The machine having high basic performance, high durability, low price and new values that lead to user benefits." KRDA will contribute to Kubota's expansion of ASEAN business by creating products conforming to this policy and concept at speed matching or exceeding expectations of contractor customers who purchase machinery or client customers who hire contractors.

Establishment of Kubota Water and Environment R&D Center USA

1. Introduction

The Water and Environment R&D and Water Engineering and Solution Division founded the Kubota Water and Environment R&D Center USA within the Canton Water Reclamation Facility in the city of Canton, Ohio in the United States. It is the first overseas research and development base in the water and environment field. This article introduces an overview of the facility and its activities.

As shown in Fig. 1, the City of Canton is located in the northeastern part of Ohio and has a population of approximately 73,000. It has a typical continental climate, with humid and hot days exceeding 30 degrees Celsius in summer and extremely cold days in winter reaching as low as -10 to -20.

In 2014, which was prior to the foundation of this facility, the Water Engineering and Solution Division received an order for the membrane units for a Membrane Bio-Reactor (MBR) system in the water reclamation facility. When completed, it will not only be the largest MBR system in North America with a processing quantity of 159,000 m³, but also a treatment system equipped with both advanced treatment that

removes nutrient salts (phosphorus and nitrogen) and a peak treatment capacity that is approximately twice that of the conventional system.



Fig. 1 Location of the City of Canton, OH

2. Overview of the facility and its purpose

As shown in Fig. 2, this facility is located inside the premises of the Canton Water Reclamation Facility.



Fig. 2 Overview of the Canton Water Reclamation Facility and Location of the R&D Center

Figure 3 shows how the building structure is divided into an office building and experimental building. The office building has an office, analysis laboratory equipped with water quality analysis devices, and an electrical room equipped with control panels and electrical facilities for the experimental equipment. The experimental building has a space to install various experimental equipment for water treatment including MBR systems.

Raw water for experiments is derived from the sewage flowing into the Canton Water Reclamation Facility and put into the raw water tank inside the experimental building.

This facility was founded for the following two purposes:

[1] Research and development of MBR systems

To conduct performance verification experiments on new MBR systems developed by the Water and Environment R&D Center in Japan using actual sewage in North America.

[2] Marketing in water and environment markets in North America

To implement marketing in the water and environment markets of North America to investigate the possibilities of business expansion and conduct various tests necessary for the development of new technologies.

As shown in Fig. 4, experimental equipment for an MBR system is installed in the experimental building and it has started operating.

In the future, we plan to carry out joint research with universities, research institutes, and equipment manufacturers in the U.S. and give presentations in academic societies.



Fig. 3 Outside View of the Facility



Fig. 4 The MBR System Test Plant

3. Conclusion

On July 19, 2016, the opening ceremony for the facility was held in the presence of many people including city officials such as the mayor and deputy mayor of Canton, people from the nearby treatment plants, the Environmental Protection Agency (EPA), construction consultants, and distributors.

There have been few precedents of research facilities founded inside the premises of a sewage treatment plant, and it was received well by the related parties, making the front page of a local newspaper.

The Water and Environment R&D Center and Water Engineering and Solution Division are currently developing various water treatment products including MBR systems to aim at global business expansion. In the future, we will fully utilize this development base so that these systems can be better suited to the local climate and water quality.

Name of facility: Kubota Water and
Environment R&D Center USA
Address: 3700 Central Ave SE, Canton, OH 44707